

Blokset

Low voltage switchboard

Installation Guide 2018

Master



General	3
Safety recommendations	3
Introduction	4
Delivery	5
Receiving	5
Packing	6
Handling	7
Storage	8
Installation	9
Tools	9
Site preparation	11
Joining sections	13
Earthing bar connection	17
Main busbar splicing	18
Connection of power cables	22
Connection of auxiliary circuits	26
Final installation procedures	28
Preliminary checks	29
Energizing equipment for the first time	30
Operation	31
Drawers	31
Operation of circuit breakers	35
Troubleshooting information	38
Maintenance	39
General maintenance	39
Preventive maintenance	42
Evolution	43
Extensions	43



Note

You have just received your new Blokset switchboard. Please read this manual carefully. It provides all the necessary information concerning installation, operation and maintenance of your switchboard.

Please keep this manual on hand for easy reference.

The messages adjacent are used in this manual to:

- Warn of potential hazards
- Draw attention to additional information intended to clarify or simplify a procedure.

 **DANGER**

Used where there is a hazard of severe bodily injury or death.
Failure to follow a "DANGER" instruction will result in electric shock, severe bodily injury or death.

 **WARNING**

Used where there is a hazard of bodily injury or death.
Failure to follow a "WARNING" instruction may result in bodily injury or death.

 **CAUTION**

Used where there is a hazard of damage to equipment.
Failure to follow a "CAUTION" instruction may result in equipment damage.

NOTICE

Used to address procedures not related to physical injury.
Provides additional information intended to clarify or simplify a procedure.

Blokset is a modular switchboard made up of a number of sections. Modular design facilitates easy transportation and installation. The horizontal busbars are connected between sections by splicing. Prior to shipping, every Blokset section is inspected visually, mechanically and electrically by a trained technician of the Quality Inspection department. A test and inspection report may be provided on request.

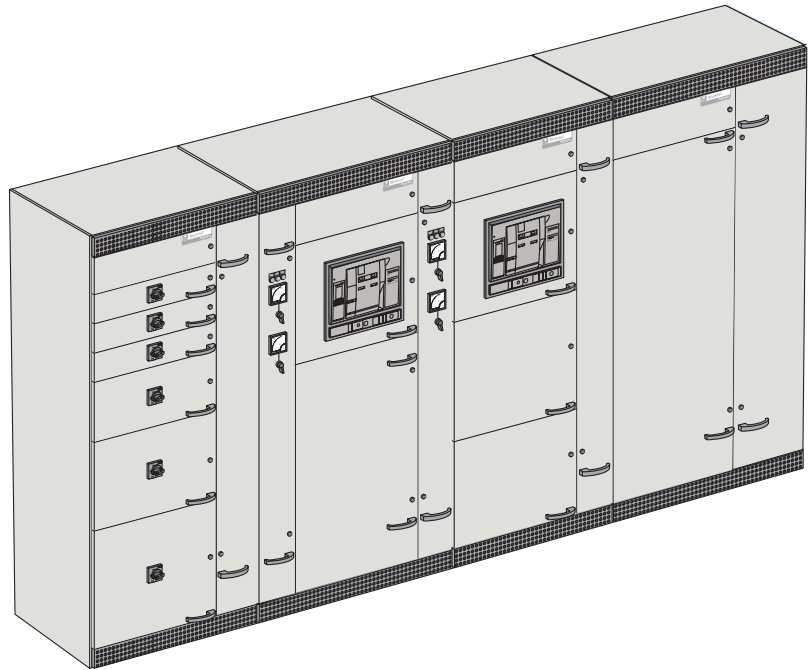

DANGER

HAZARD OF ELECTRIC SHOCK, BURNS OR EXPLOSION

- Correct operation of the Blokset switchboard requires that handling, installation, operation and maintenance be carried out exclusively by a qualified personnel.
- The system must be de-energized prior to installation and maintenance operations to avoid exposing personnel to the risk of an electrical shock.
- The purpose of this instruction manual is to familiarise qualified personnel with Blokset construction, installation and maintenance as well as the risks encountered. Personnel must be:
 - Qualified to work near live equipment.
 - Trained with respect to all applicable safety practices.

Failure to observe these instructions will result in severe bodily injury or death and damage to the switchboard.

Check the switchboard nameplate located on the incoming section for conformity with the delivery note.

- On receipt of the equipment and before handling it, check that the cases and packing materials used for transportation have not been damaged and that all items on the packing list have been effectively delivered.
- Even if the packing appears to be in good condition, do not hesitate to unpack the equipment in the presence of an authorised transport agent.
- Check consignment contents and weight. Thoroughly check the equipment to make sure that no damage or shocks have occurred which may impair insulation or operation.
- If necessary, check that the information given on the switchboard nameplate, located on the incoming section, conforms to that given on the delivery slip.
- In case of damage or missing parts, inform the transport agent by registered mail.

NOTICE
We absolutely decline any responsibility for losses or damage during transportation and any financial liability for said losses and damage.

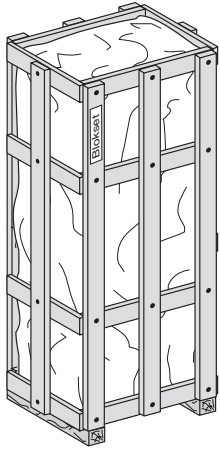

Fig. 1 : Standard packing

Blokset is generally shipped in transport units made up of one or several joined vertical sections.

Two types of packing used for shipping are:

■ **Standard packing**

The transport unit is wrapped in a sheet of plastic and crated (see Fig. 1).

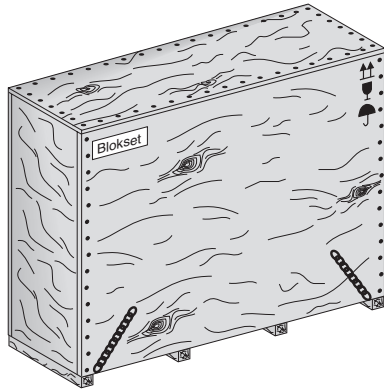

Fig. 2 : Ship packing

■ **Ship packing**

Desiccant packets are placed inside the equipment, which is then wrapped in a heat-sealed plastic sheet, and placed in a ventilated box made of wood or plywood (see Fig. 2).



Fig. 3 : Handling with a forklift

■ The equipment is delivered on pallets or skids. Final unpacking of the equipment should take place, if possible, just before the installation. Equipment dimensions and weights are indicated on the packing.

■ **The equipment may be handled from:**

□ **The bottom**

The equipment may be lifted from the front or back by a pallet-mover or a forklift. Care must be taken during lifting and the equipment must be secured by a safety strap during transport (see Fig. 3).

□ **The top**

When overhead cranes are used, slings are required. They must be strong enough and in good condition. The slings must always be connected to the four lifting rings on the equipment. Adjust the length of the slings to the size of the switchboard such that the angle between slings does not exceed 60° (see Fig. 4).

■ **In special cases** where the transport unit includes more than two interconnected sections, **it is necessary to:**

- Reinforce the mechanical connections between sections
- Use a lifting beam with direct connections to the switchboard support items (see Fig. 5).

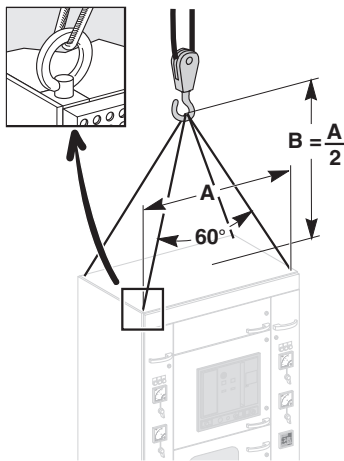

Fig. 4 : Handling with slings

To hoist a double front column, assemble the lifting L angle in the holes indicated with M12 Bolts (see Fig. 6).

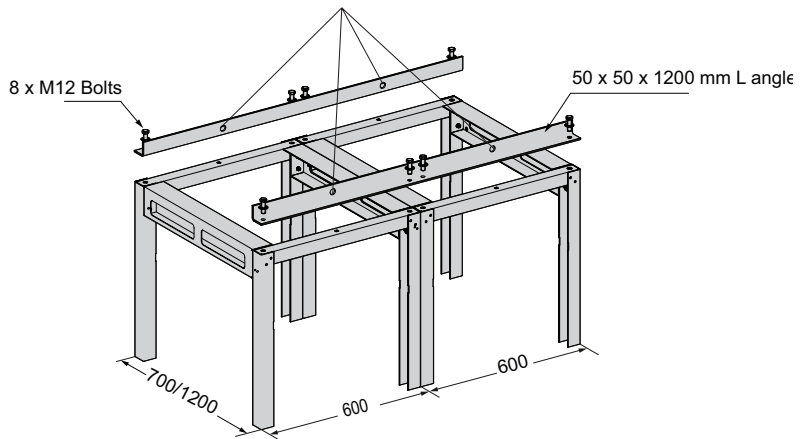
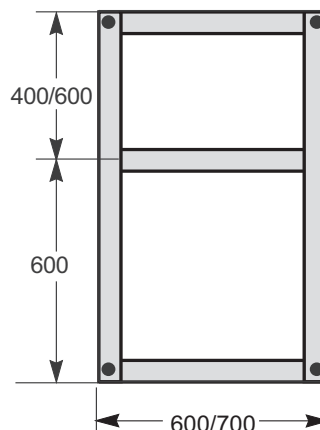
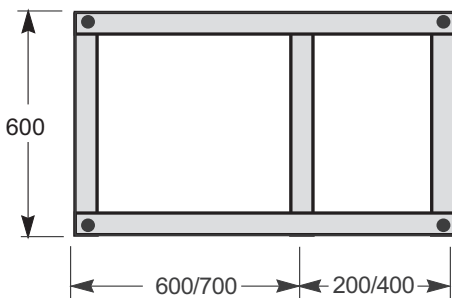

Fig. 6 : Double front cubicle lifting

A locally developed 50 x 50 x 1200 mm L angle is to be used for lifting a double front assembly.



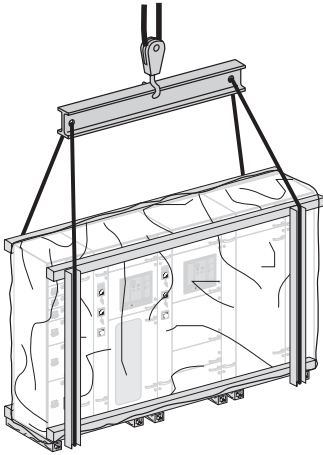

Fig. 5 : Handling joined sections.

⚠ WARNING

HAZARD OF FALLING

Use extreme caution when moving the equipment. There is a tendency for the equipment to tilt due to its high centre of gravity.

Failure to observe these instructions may result in bodily injury or damage to the equipment.

- Blokset is intended to be used indoors. The equipment must therefore be stored upright in a dry and ventilated location, protected from rain, extreme temperatures, streaming, dust, and chemical agents.
- Never store Blokset outside, even under a tarpaulin.
- The columns must preferably remain packed until they are installed. During work in progress, columns should be covered, to protect them efficiently against dust, gravel, paint, and cement.
- Acceptable storage temperature is between -25°C to +70°C.
- To ensure easy, risk-free handling, the columns, due to its enormous weight, must be stored on a stable or rigid floor.

 CAUTION
HAZARD OF RUST Never store Blokset equipment outdoors, even if covered by a tarpaulin. Failure to follow this precaution, can result in damage to the equipment.

Required Tools

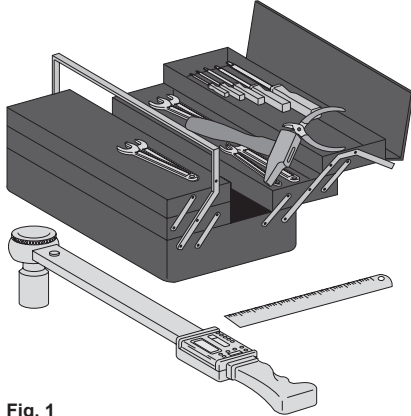

Fig. 1

Specific tool



Fig. 2

General tools:

- 75 N.m torque wrench
- Bush ratchet
- Bush of 10
- Bush of 13
- Bush of 16
- Bush of 17
- Bush of 18
- Bush of 19
- Torx 8 bit
- Torx 10 bit
- Torx (8 and 10) and recess screwdriver or screwing/ unscrewing machine, with appropriate bits
- Clamps for column alignment
- Rubber mallet
- Hydraulic jacks that can operate in horizontal position and are used to lift the columns and, if necessary, move them sideways.

■ Torque wrench features:

- Tightening torque : 75 N.m
- It has a reduced thickness, can be easily used to access non accessible joints/fishplates and between busbars.

■ Torque wrench:

- Tool accessories:
 - Wrench shaft - mandatory
 - Extra-thin pawl adapter - mandatory
 - Pawl for ordinary sockets, optional (to be fitted on the SP3723 shaft)
- Extra-thin sockets for pawl + shaft:
 - 13 mm extra-thin low socket
 - 13 mm extra-thin high socket
 - 16 mm extra-thin low socket
 - 16 mm extra-thin high socket
 - 17 mm extra-thin low socket
 - 19 mm extra-thin high socket
 - 19 mm extra-thin low socket

■ Busbar trunking conversion modules special tip:

- Indispensable extended tip for tightening the conversion modules on the busbar trunking junction blocks.
- It fits on an ordinary torque wrench.

Tools for various assembly types

- Splicing: busbars
 - Bush of 16 and 17 for M10 screw
- Assembling: columns
 - Bush of 10 for M6 screw
- Floor fixing:
 - Bush of 16 and 17 for M10 screw
- Fitting the roofs and lifting lugs:
 - Bush of 19 for M12 screw

Material

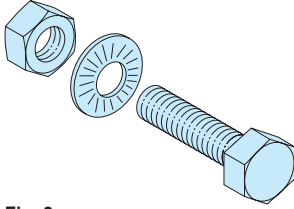

Fig. 3

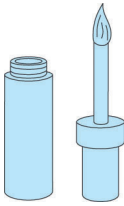

Fig. 4

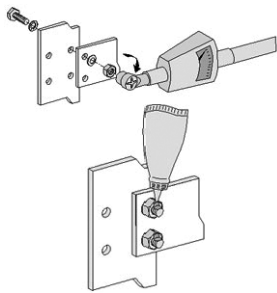

Fig. 5

- 8.8 quality steel, according to ISO 898-1 standard.

Recommended tightening torque for mechanical and electrical links with 8.8-class screws (with nut + contact washer)

Diameter of screw	Tightening torque (N.m)
M3	1.5
M4	3.5
M5	7
M6	13
M8	28
M10	50
M12	75
Nut for insulated rod	2

Tightening torque for electrical links on the devices and for their fixing:

- Refer to the device handbook.

Marking varnish:

- After tightening each electrical connection to the appropriate torque, apply some varnish:

- Between the nut and the screw or
- Between the screw head and the copper bar or
- Between the device for tightening on a threaded part

- Varnish should not block the screw:

- It allows operator inspection, to verify if the bolts/ nut are tightened or not.
- It facilitates the identification of any loose nuts during the switchboard's lifetime.

Varnish features:

- Coloured acrylic varnish, indelible and able to resist a 150° C temperature.
- Schneider Electric recommends a red varnish as a standard to identify the panelbuilder's work.
- Other colours can be used by the contractor or any operators entitled to work on the switchboard after its commissioning.

- The Blokset installation site must be clean. The floor must be flat and level deviations (≤ 2 mm/m) (see Fig. 6).
- Leave at least 1200 mm of free space (see Fig. 6), to enable the opening for the doors and operator access.
- At least 1200 mm (or 1600 mm for 6300 A) of free space (see Fig. 6) must be left in front of Blokset to allow the doors to open completely, maintenance or, wherever applicable, use of a lifting device.
- Leave space for future extensions.
- Connection through the top.
 - Provide at least 600 mm of free space above Blokset.
- Connection via the bottom (see Fig. 7).
- Two possibilities for routing the cables:
 - Through a trench located under the equipment. The depth must be at least 600 mm to take into account the minimum bending radius of the cables.
 - Under a false floor. In this case, a hole must be made in the floor for cable routing.

 **DANGER**

HAZARD OF ELECTRIC SHOCK, BURNS OR EXPLOSION.

A hazard of electric shock, burns or explosion exists both inside and outside the equipment. Turn off all power supplying the equipment before working on it.

Failure to observe these instructions will result in electric shock, severe personal injury or death.

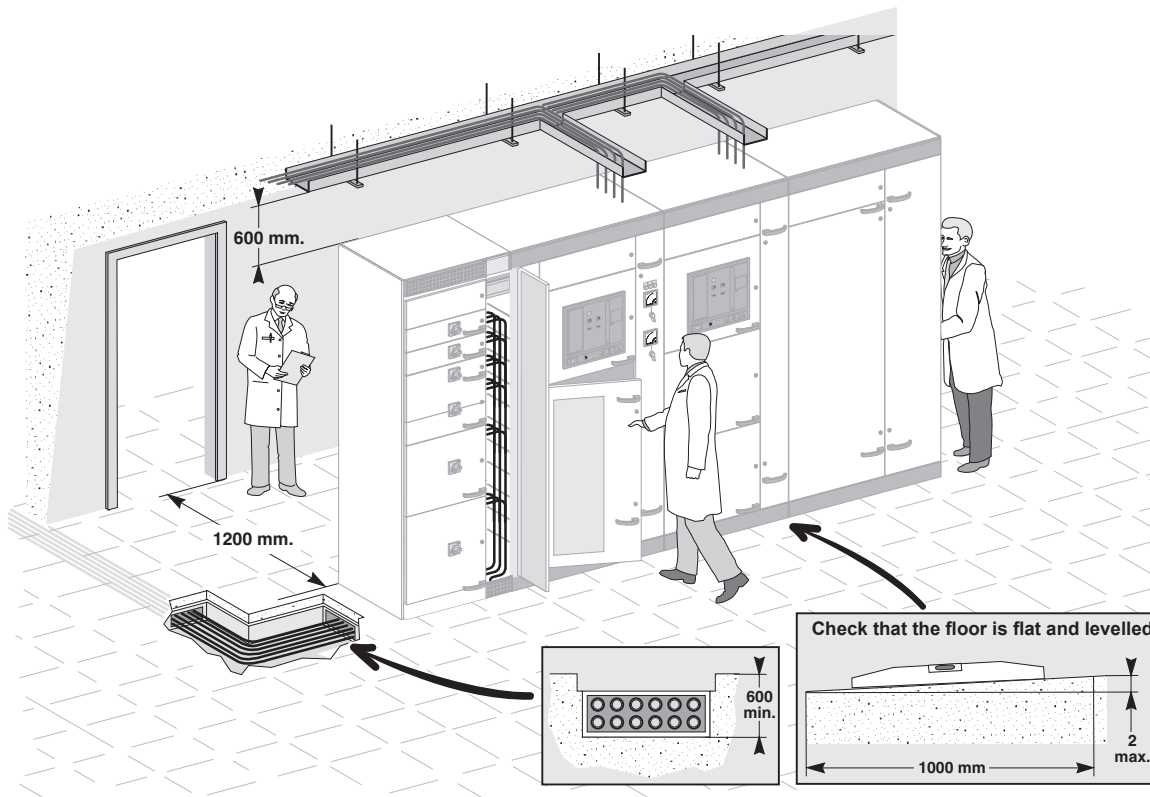

Fig. 6: Opening for cable routing via the bottom

Opening for cable routing

Fig. 7 : Blokset type D, Mf, Ms
Depth of section 400 or 600 mm

A: 250 for a depth of 400 mm
450 for a depth of 600 mm

Section width 700

Section width 900 (200 + 700)

Section width 1100 (700 + 400)

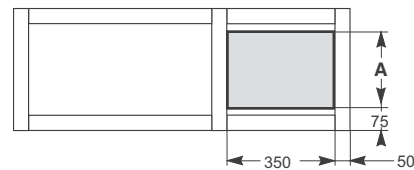
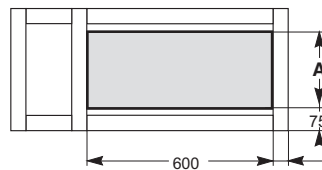
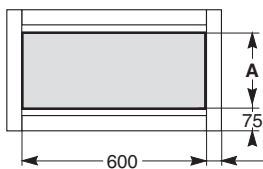

Section width 1100 (200 + 700 + 200)

Section width 1200

Section width 1300 (200 + 700 + 400)

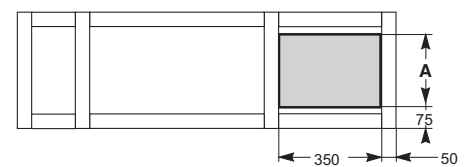
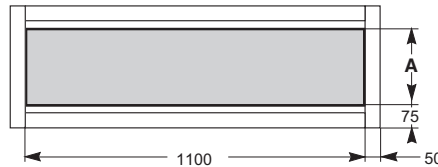
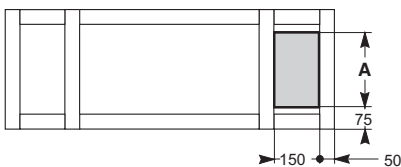

Blokset type Mw2

Section depth 600 mm

Section width 800, 900 or 1000 mm

Section depth 1000 mm

Section width 800, 900 or 1000 mm

Section width 600 mm

B: 175 for a width of 800
275 for a width of 900
375 for a width of 1000

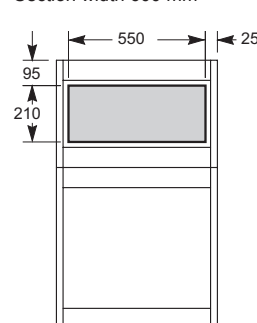
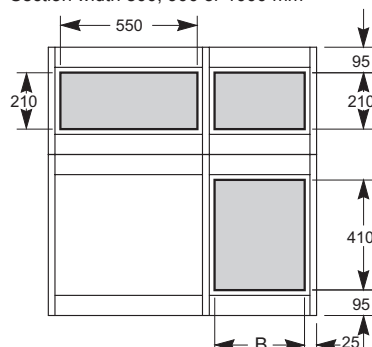
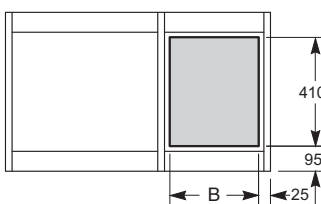

- Position the sections on the installation site in the desired order of assembly.
- Remove any remaining packing and protection.
- Remove the cover panels and parts to facilitate access for switchboard assembly. Note the position of the various parts.
 - Remove the side panels (see Fig. 8):
 - Remove the screws securing the panel.
 - Lift the panel to free it from its supports and pull it away.
 - Remove the upper and lower ventilation grates:
 - First tilt the grate forward to unclip it from the frame (see Fig. 9a).
 - Now pull it forward to free it completely (see Fig. 9b).
 - Remove the doors (see Fig. 10a to 10e):

Fig. 10a and 10b: Open the door.

Fig. 10c: Free the blocking stud by pulling it down.

Fig. 10d: Pivot the blocking stud a quarter-turn with respect to the door.

Fig. 10e: Remove the door.

- The sections can be installed starting from right to left, or left to right or beginning with a central section.

WARNING

HAZARD OF FALLING

Use extreme caution when moving the equipment. There is a tendency for the equipment to tilt due to its high centre of gravity.

Failure to observe these instructions may result in bodily injury or damage to the equipment.

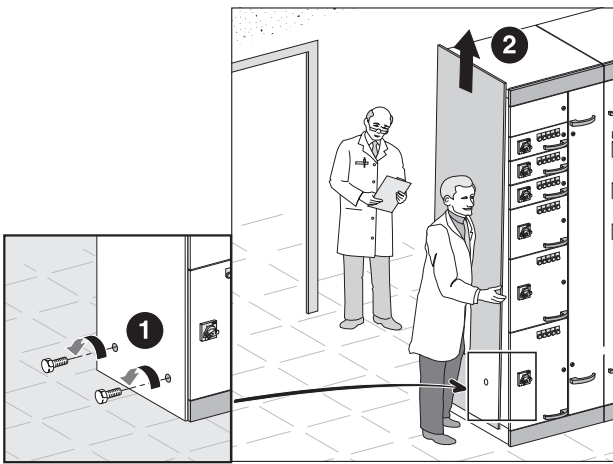

Fig. 8

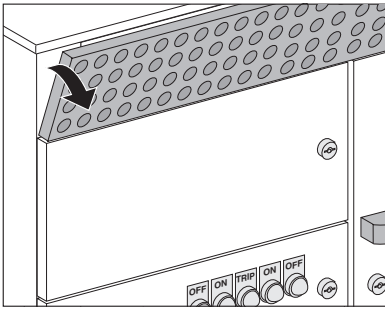

Fig. 9a

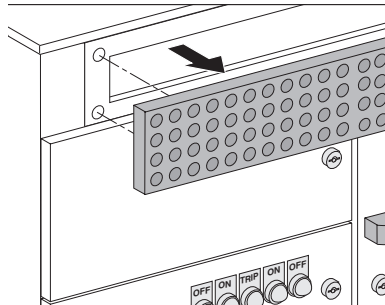

Fig. 9b

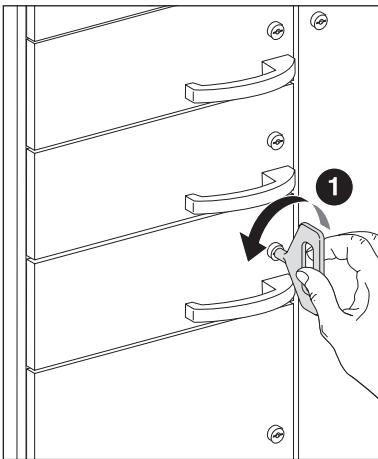

Fig. 10a

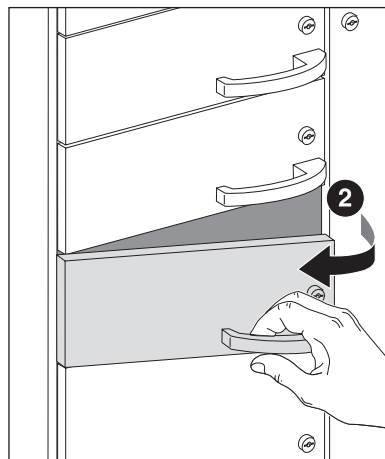

Fig. 10b

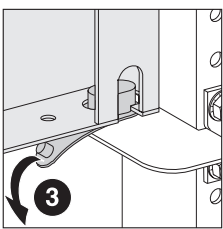

Fig. 10c

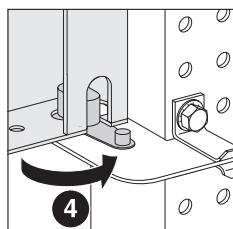

Fig. 10d

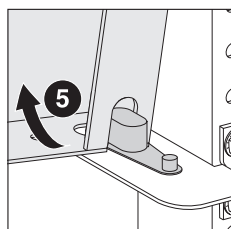

Fig. 10e

- Position the first section and secure it to the floor using three M10 anchor bolts (see Fig. 11 and 12).
Figure 13, shows the locations of the holes that must be drilled for the anchor bolts.
- Position the second section next to the first.
- Secure the second section to the floor using two M10 anchor bolts at diagonally opposite corners (see Fig. 11).
- Interconnect the two sections using eight M6 x 16 bolts and 6 mm diameter barbed washers. Use class 8.8 nuts and bolts.
- Proceed in the same manner for the other sections.

NOTICE

If the floor is not perfectly flat, chock the sections before securing them.

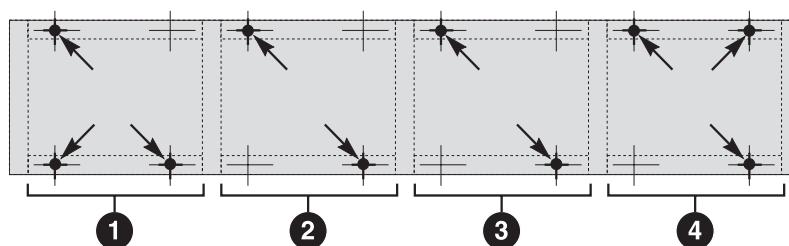

Fig. 11

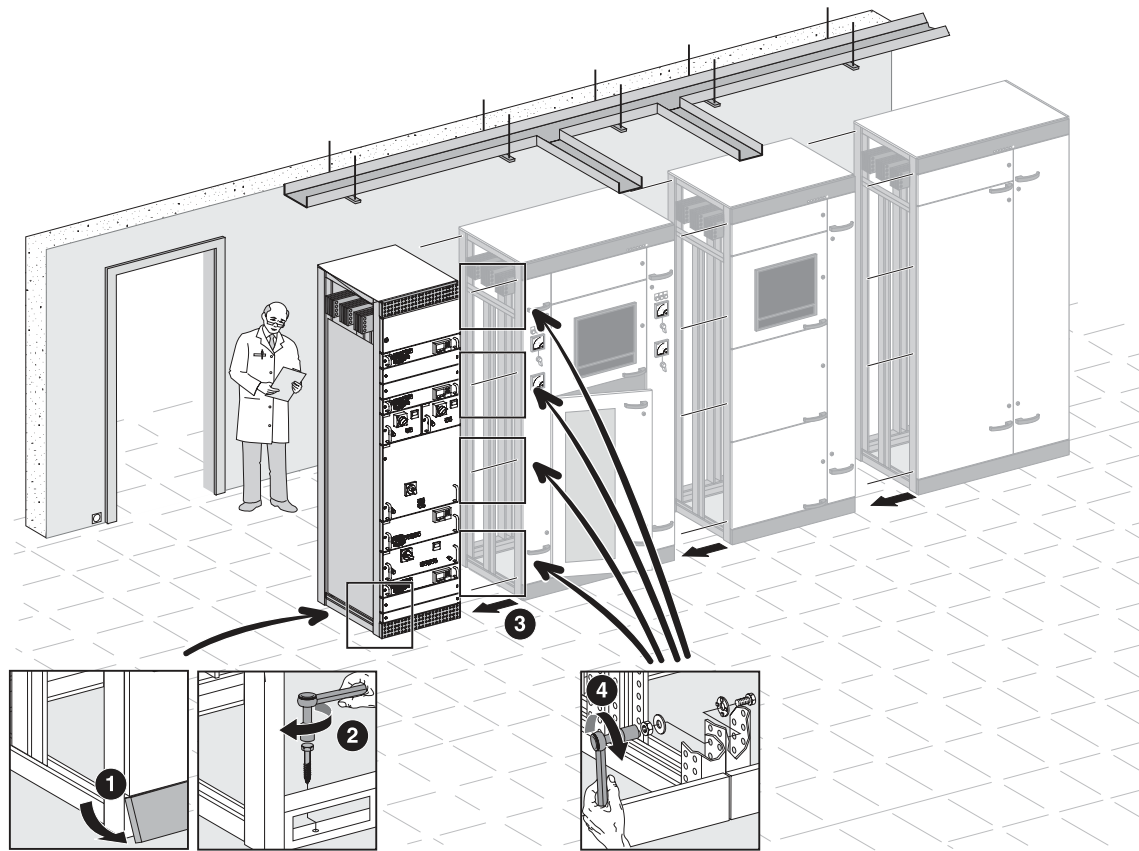
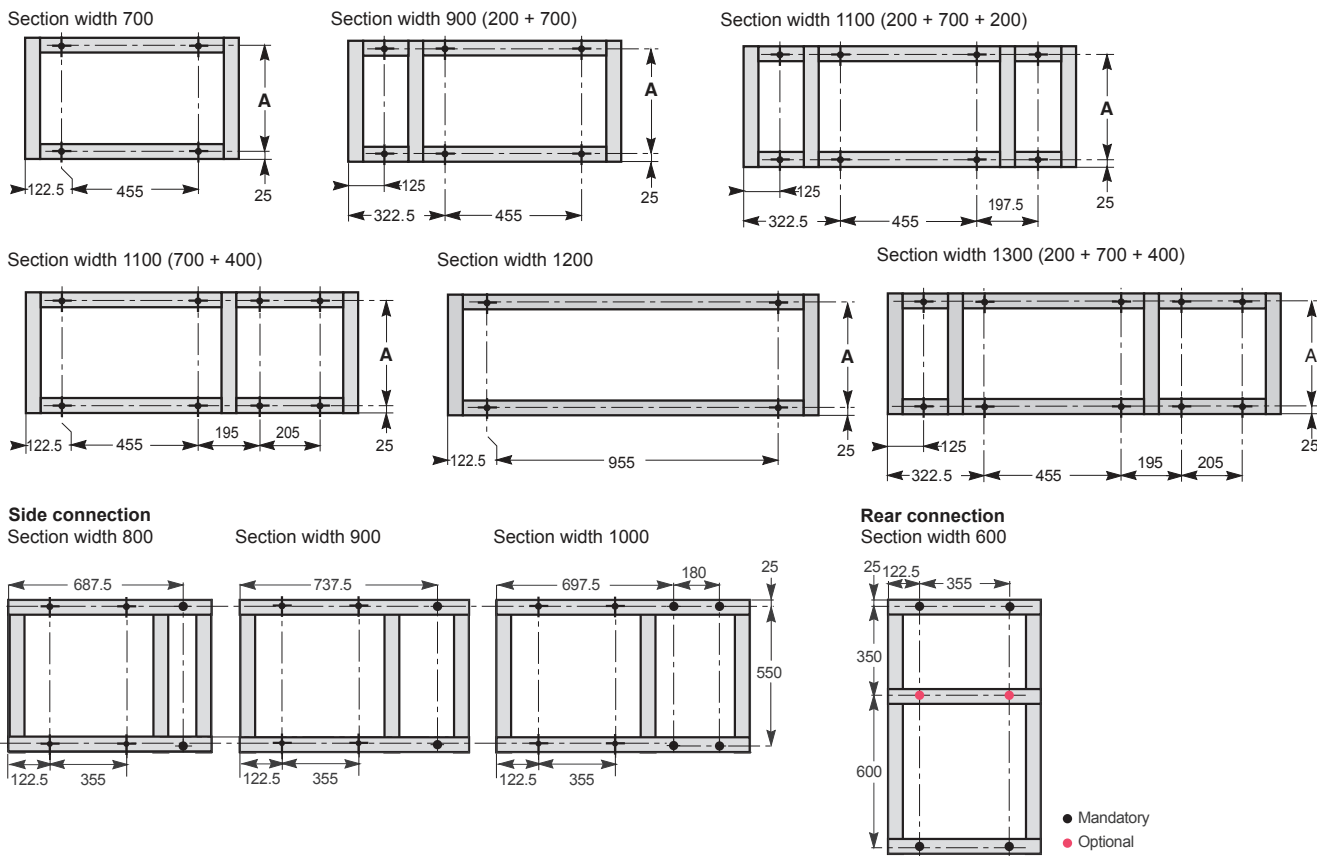

Fig. 12 : Joining sections

Fig. 13 : Depth of section 400 or 600 mm

A : 350 mm for a depth of 400 mm
 550 mm for a depth of 600 mm
 950 mm for a depth of 1000 mm



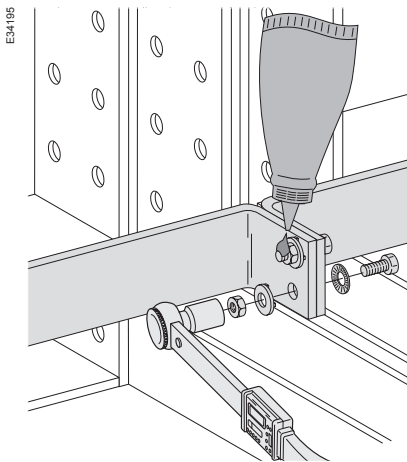

Fig. 14

- The earthing bars of the various sections are connected together using class 8.8 nuts and bolts (see Fig. 14).

Assemble the bars using M10 x 30 bolts with contact washers and tighten the nuts as indicated hereunder using a torque wrench. After tightening, mark each nut with a drop of varnish (see Fig. 14).

Tightening torque for class 8.8 nuts and bolts	
Hexagonal Bolt diameter	Tightening torque (Nm) nut with contact washer
M6	13
M8	28
M10	50

E34196

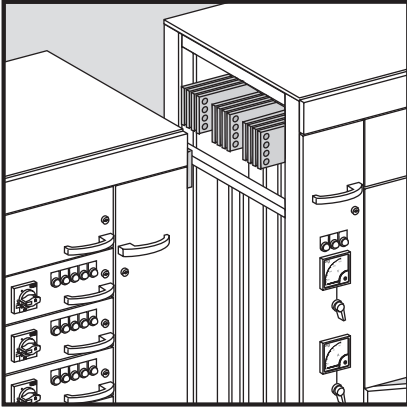

Fig. 15 : Sliding fishplate

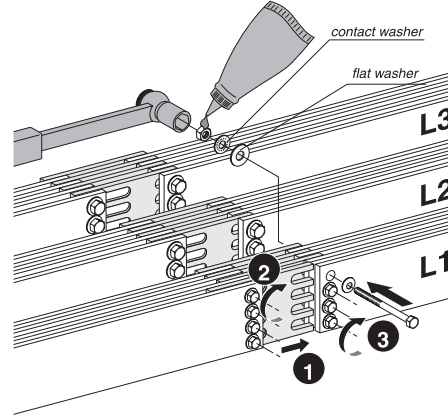

Fig. 16 Sliding fishplates

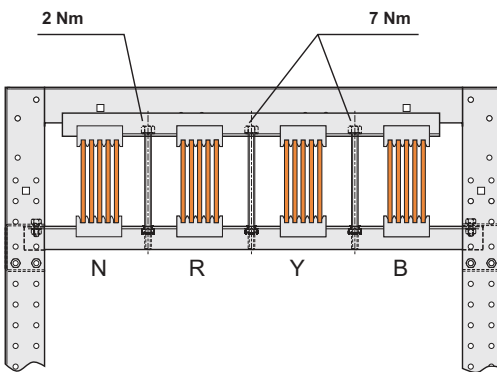

Fig. 17

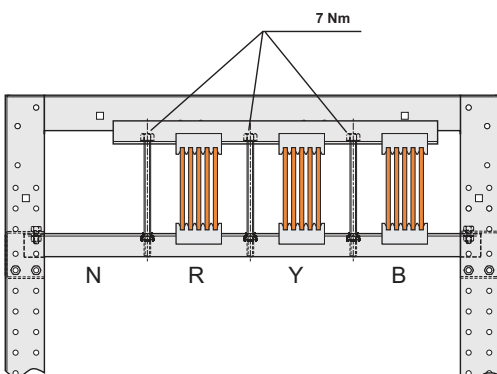

Fig. 18

■ Joining with sliding fishplates (see Fig. 15 and 16):

- The sliding fishplates are assembled on the horizontal busbars.
- Tighten all the nuts to the indicated tightening torque using a torque wrench.
- Once tightened, mark each nut with a drop of varnish.

The length of the bolts depend on the number of bars to be joined as indicated hereunder.

Recommended bolt length		
Number of bars to be joined	Bar thickness: 5 mm	
	Minimum	Maximum
2	25	30
4	35	40
6	50	60
8	60	60
10	65	70

- Tighten the nuts using a torque wrench (refer to page 17).
- After tightening, mark each nut with a drop of varnish.

During the installation and commissioning, for an easier access while performing the busbar fishplating process, the busbars supporting cross members (aluminium) can be temporarily removed. After actual fishplating, they must be re-installed at the same position and re-tightened with torques as indicated in Fig. 17 and Fig. 18.

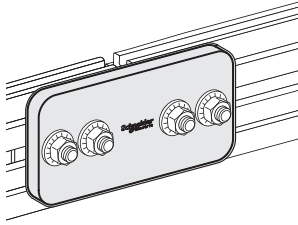

Fig. 19: Horizontal non-sliding fishplate option for linergy busbars

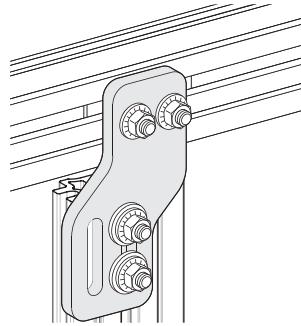

Fig. 20: Vertical non-sliding fishplate option for linergy busbars

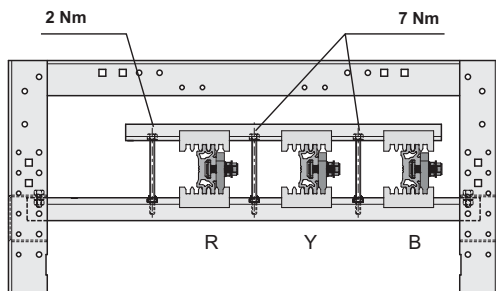

Fig. 21

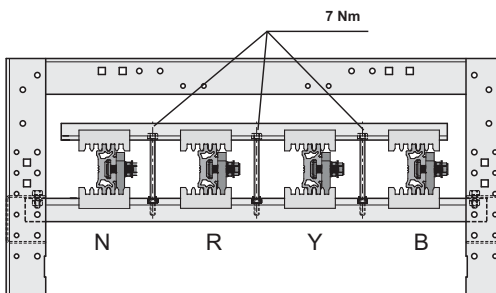

Fig. 22

■ **Joining linergy bars with horizontal non-sliding fishplate (see Fig. 19):**

- The non-sliding horizontal fishplate is assembled on the horizontal busbars.
- Tighten all the nuts to the indicated tightening torque using a torque wrench.

■ **Joining linergy bars with vertical non-sliding fishplate (see Fig. 20):**

- Connect the vertical busbars as indicated.
 - Position the vertical fishplate.
 - Align the holes for bolting.
 - Fit the bolts, contact washers and nuts.

During the installation and commissioning, for an easier access while performing the busbar fishplating process, the busbars supporting cross members (aluminium) can be temporarily removed. After actual fishplating, they must be re-installed at the same position and re-tightened with torques as indicated in Fig. 21 and Fig. 22.

NOTICE

The non-sliding fishplate are supplied in a box inside the section. Begin connections on the bars for phase 3, to ensure easy mounting of the bolts.

The nuts used to assemble the vertical non-sliding fishplate, break off once tightened to the required torque value.

Fishplate Assembly for horizontal linergy busbars

To assemble the fishplates for horizontal busbars, follow the below steps:

1- Position the inserts (ref. S1A91784) inside the busbars (see Fig. 23).

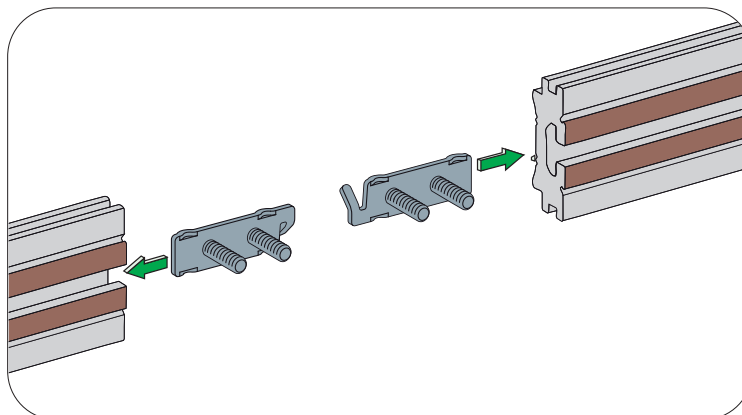

Fig. 23

2- Move both the busbars together, to maintain a zero clearance between the inserts (see Fig. 24a and Fig. 24b).

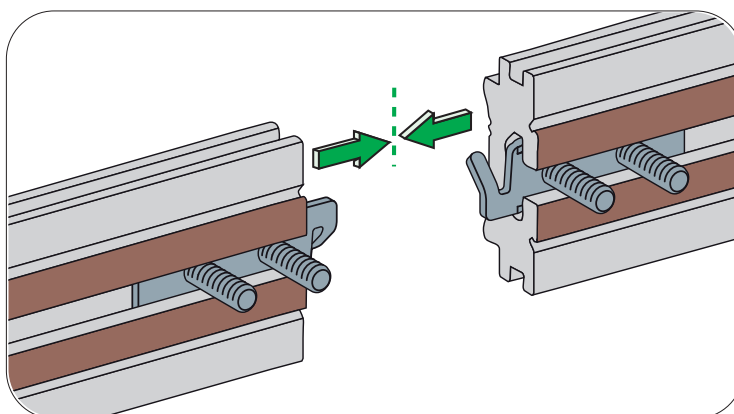

Fig. 24a

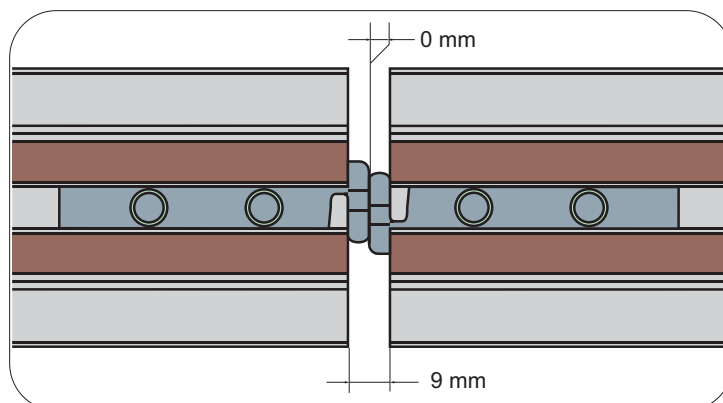

Fig. 24b

3- Align the holes for bolting. Fit the bolts, contact washers and nuts. Tighten nuts using a torque wrench as shown (see Fig. 25a).

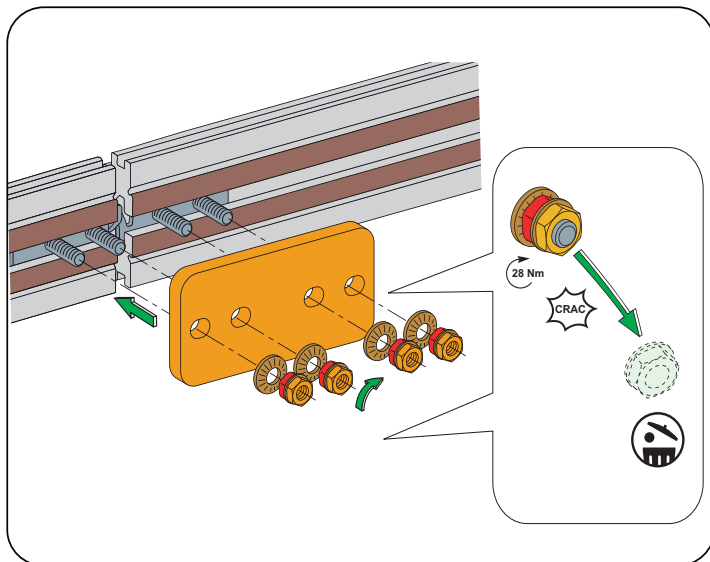

Fig. 25a

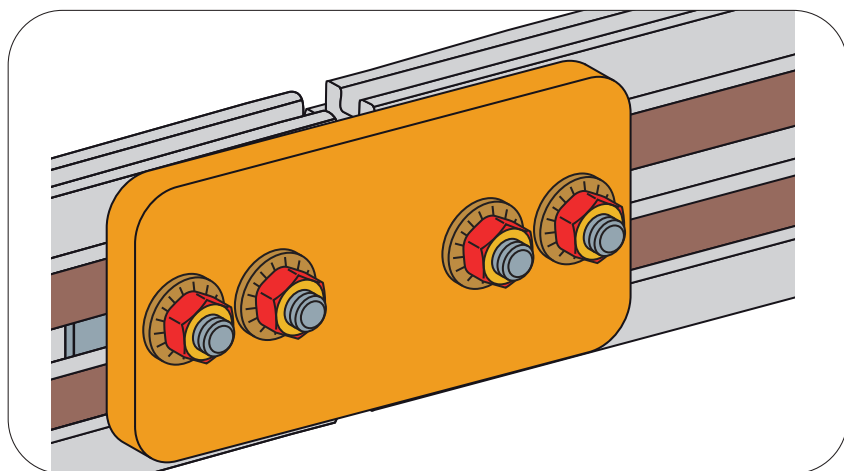

Fig. 25b

⚠ DANGER

HAZARD OF ELECTRIC SHOCK, BURNS OR EXPLOSION

Turn off the power supply to the equipment before working on it. A hazard of electric shock, burns or explosion exists whenever working in or around the equipment.

Failure to observe these instructions will result in severe bodily injury or death.

NOTICE

- Cables must never touch or run between live conductors (copper bars, etc.).
- When bending cables, observe the minimum bending radius (six to eight times the cable diameter).

- First connect the Blokset earthing bar to the earth electrode to ensure the protection of the personnel.
- Care must be taken when installing the cables to avoid placing any mechanical strain on the connection terminals of the equipment.
- Connections through the top.
 - Remove the roof or the cable gland plate.
 - Drill the holes required to install the cable glands or grommets.
 - Install the cable glands. They must comply with high IP protection degrees.
 - Put the roof or the gland plate back on Blokset.
 - Run the cables through the glands.
 - The cables must run in the intended ducts and be secured to cable tie-bars every 400 mm (see Fig. 26).

Bundle cables circuit by circuit. The number of cables in each bundle depends on the diameter of the cables (see Fig. 26).

Cable cross-sectional area (mm ²)	Number of cables per bundle
≤ 10	8
16 to 50	4
> 50	Tie individually

The distance between the cable ties depends on the electro-dynamic forces and the type of tie used.

Type of tie	Maximum I _{sc} (kA rms)	Distance between ties (mm)
Width: 4.5 mm Max. load: 22 kg	10	200
	15	100
	20	50
Width: 9 mm Max. load: 80 kg	20	350
	25	200
	35	100
	45	70

- Connection through the bottom
 - Remove the bottom plate (see Fig. 26A).
 - Drill the holes required to install cable glands or grommets.
 - Install the cable glands. They must comply with high IP protection degrees.
 - Remount the bottom plate.
 - Run the cables through the glands (see Fig. 26B).
 - The cables must run in the intended ducts and must be secured to cable tie-bars every 400 mm.
 - If the bottom plate is not used, the cables must be secured to a tie-bar at the bottom of the section (see Fig. 26C).

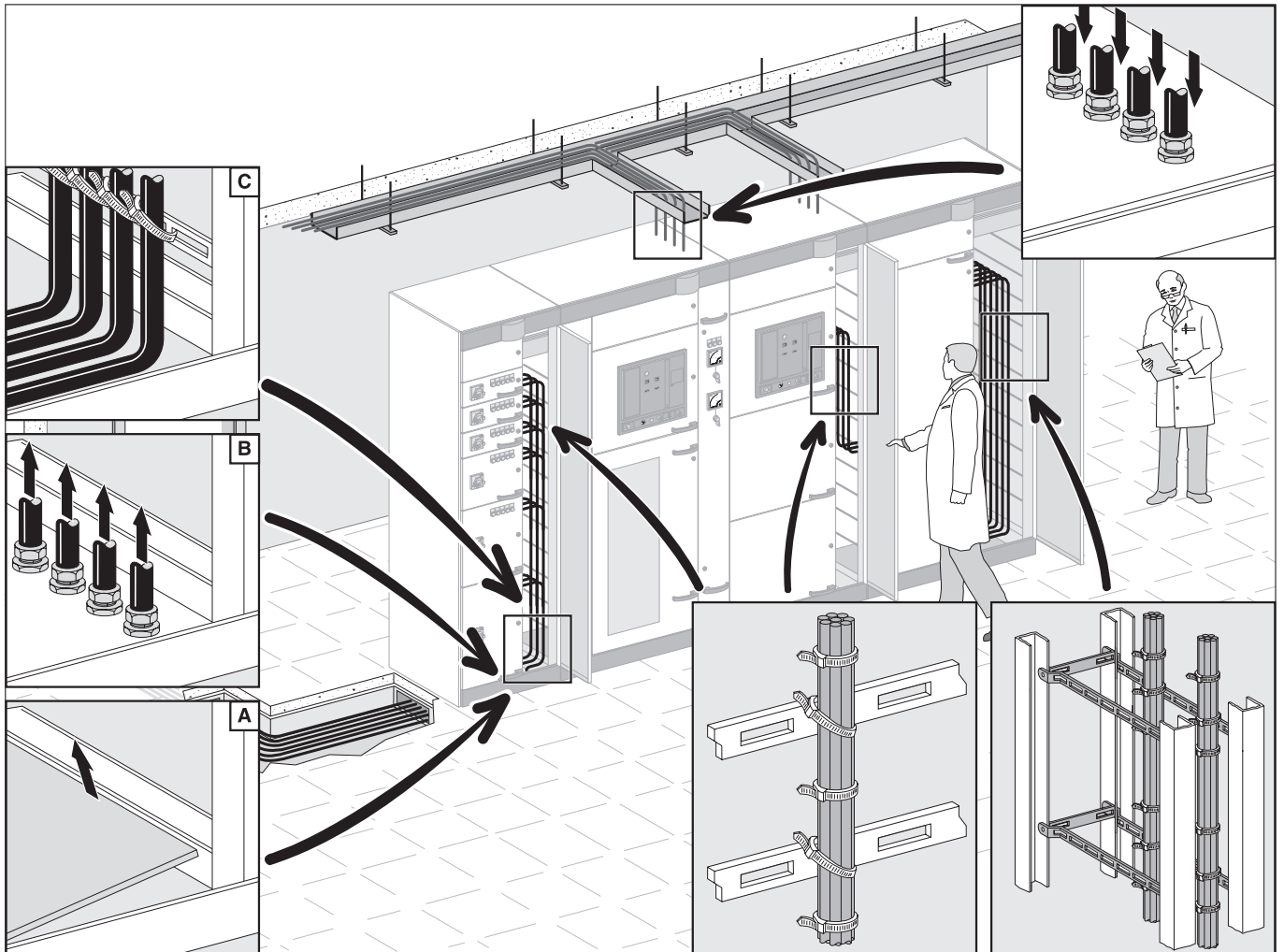

Fig. 26

- A: Removal of the bottom plate.
- B: Incoming cables through the bottom with bottom plate and cable glands.
- C: Incoming cables through the bottom without bottom plate.

- Connection of cables to the ends of the copper bars:
 - Lugs are used for connections to the ends of the copper bars (see Fig. 27). If connections are made with aluminium cables, use bi-metal lugs.
 - When connections are made to several bars for each phase, position the lugs opposite one another and insert the copper spacers supplied with Blokset (see Fig. 27).
 - All connections must be made with class 8.8 hardware and tightened as indicated hereunder.

Tightening torque (Nm)	
Nominal diameter of bolt	Nut with contact wash
M3	15
M4	35
M5	7
M6	13
M8	28
M10	50
M12	75
M14	120
M16	185
M18	260
M20	370

After tightening, mark each nut with a drop of varnish.

- Connection of cables directly to device terminals:
When connections are made directly to the device terminals, different tightening torques must be observed, depending on the various devices as indicated hereunder.

Tightening torque (Nm)	
Circuit breaker	Nut with contact washer
Compact NS80	4.5 ($\leq 6 \text{ mm}^2$)
	5.6 ($> 6 \text{ mm}^2$)
Compact NSX100	10
Compact NSX160/250	15
Compact NSX400/630	50
Easypact CVS100	1
Easypact CVS160/250	1.5
Easypact CVS400/630	5

NOTICE
Respect the safety clearances for devices as defined by the manufacturer to guarantee correct operation.



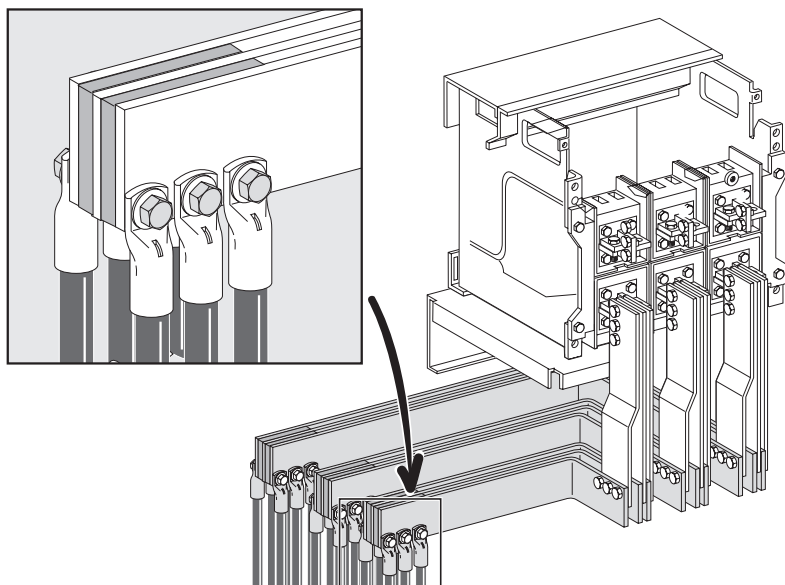
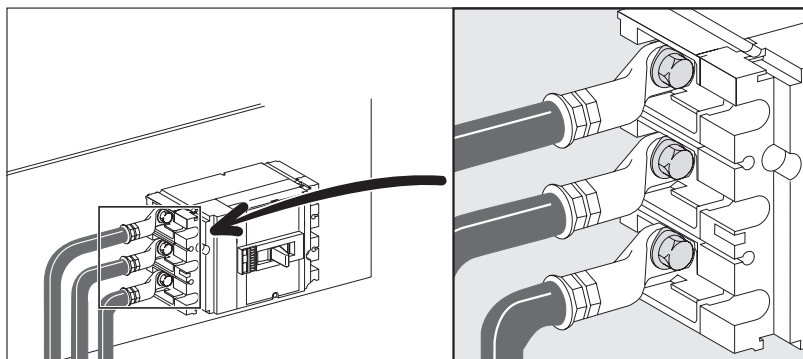

Fig. 27



NOTICE
<ul style="list-style-type: none">■ Auxiliary circuits must be separated from power circuits.■ Wherever possible, cables should run in trunking.

- Running cables in trunking:
 - Trunking must be secured at least every 600 mm (see Fig. 28).
 - Trunking must not be filled to more than 70% of capacity.
 - Cables must not be tied inside trunking.

NOTICE
Trunking must be secured using plastic screws to avoid any risk of damaging cables.

- Connections must be made to terminals:
 - All strands of a conductor must be inserted in the hole of the terminal (see Fig. 29).
 - Tighten securely, to ensure not to cut the strands.
- Conductors must be shielded (see Fig. 30):
 - Connect the cable shielding to earth.

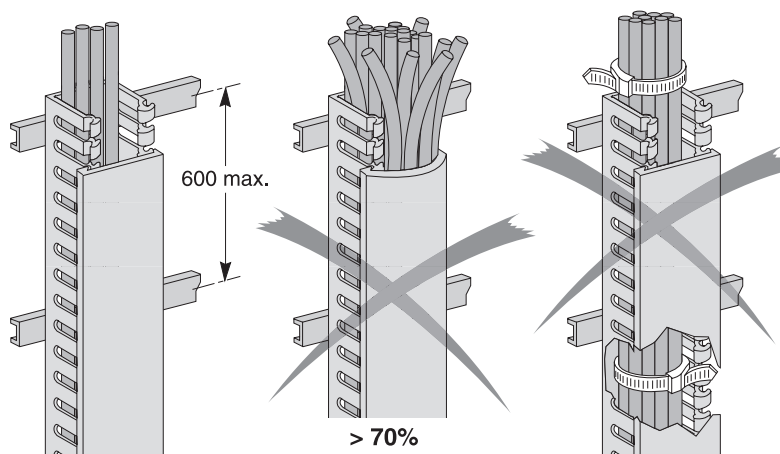

Fig. 28

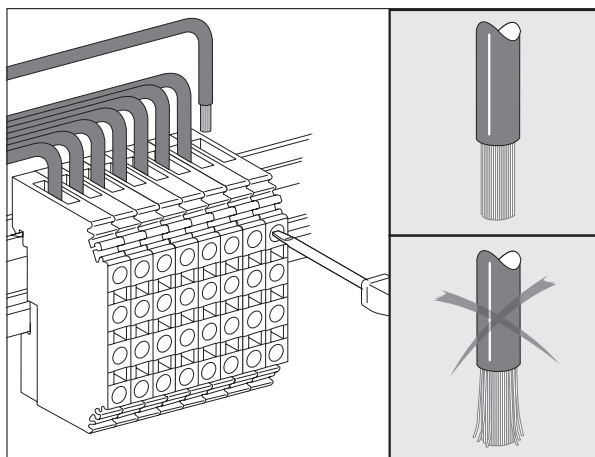

Fig. 29

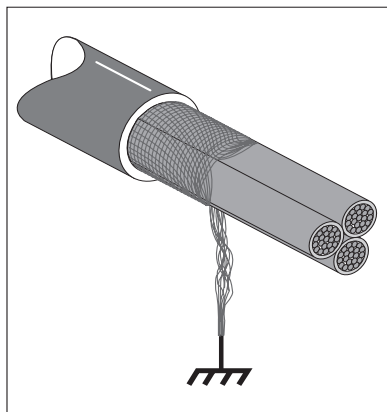

Fig. 30

- Reinstall the ventilation grids, the side panels at each end and the doors in their initial position.
- Create an equipotential connection for the doors using a green/ yellow wire (see Fig. 31).
- Install the withdrawable devices (Masterpact/Easypact, Compact):
 - **Masterpact/Easypact**
 - Unpack the devices.
 - Check that they have suffered no damage that might inhibit correct operation.
 - Remove the two securing brackets (see Fig. 32).
 - Before racking in the Masterpact/Easypact, check that the chassis correspond to the device.
 - Pull on the rail extraction handles (see Fig. 33).
 - Position Masterpact/Easypact on the rails (see Fig. 34).
 - Make sure the device rests on all four supports.
 - Push on the extraction handles to insert Masterpact/Easypact in the chassis (see Fig. 35).
 - **Compact**
 - Consult circuit breaker documentation and the operating manuals.

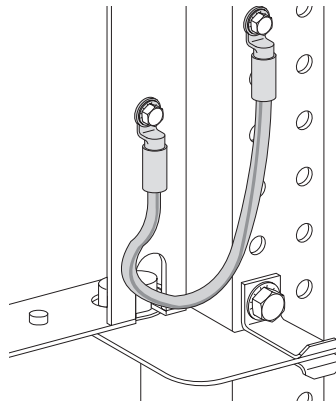

Fig. 31

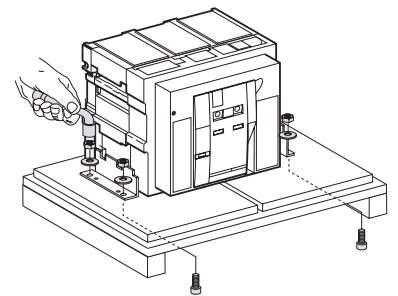

Fig. 32

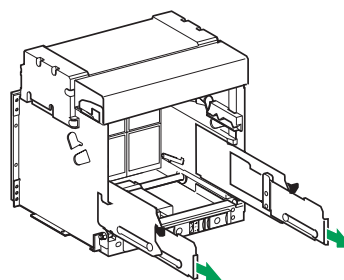

Fig. 33

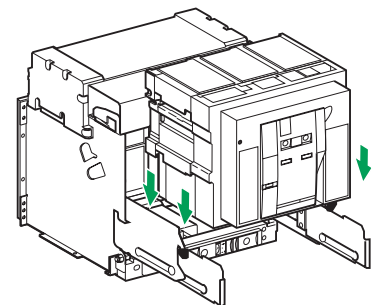

Fig. 34

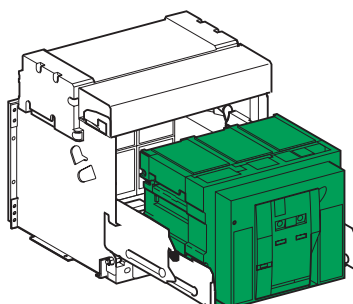
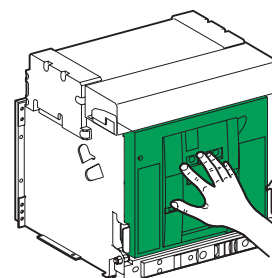

Fig. 35



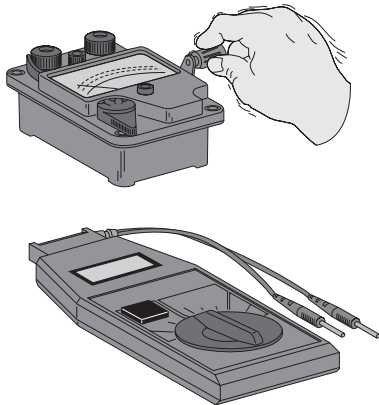

Fig. 36

- Remove all foreign objects that may disturb switchboard operation (cable scraps, wires, nuts and bolts, tools, and so on).
- Vacuum the entire switchboard to remove dust.
- Check the insulation of auxiliary circuits using an electromagnetic generator.
- Check operation of the auxiliary circuits in the switchboards:
 - Energize and carry out operating tests for the various sequences.
- Carry out overall insulation measurements.

If a TNC earthing arrangement is used, disconnect the earth electrodes before carrying out the insulation measurements. Measurements should be carried out using an insulation tester and with the system supplied by a voltage of at least 500 Vdc.

The insulation-resistance value must be equal to at least 1000 Ω/V . If the overall insulation value is low, preheat the switchboard using a source of heat (resistor, light bulb) for at least 24 hours to remove humidity, then carry out the overall insulation measurements again.

- Dielectric tests have already been carried out in the factory (see the factory test report).

Final connections and checks:

- Reconnect the earth electrodes that were disconnected for the insulation and dielectric measurements.
- Check the electrical continuity of the various exposed conductive parts of the assembly (presence of contact washers, presence of equipotential connectors for doors, etc.).
- Check, using a torque wrench, the tightness of all electrical connections, mechanical connections and anchor bolts.
- Miscellaneous checks include:
 - Mechanical locking of switchgear devices.
 - Markings on the switchboard, on power and control conductors.
 - Visual inspection of outside surfaces and paintwork.
- Touch up any scratches or other defects.
- Lightly grease the electrical contacts (according to the breaker manufacturer's instructions).

⚠ CAUTION

RISK OF EQUIPMENT DAMAGE

Dielectric tests subject the equipment to certain stresses (ageing) and should not be carried out frequently.

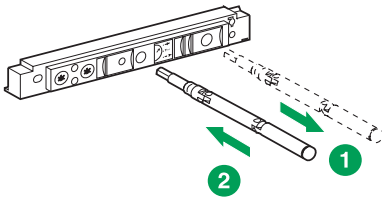

Fig. 37

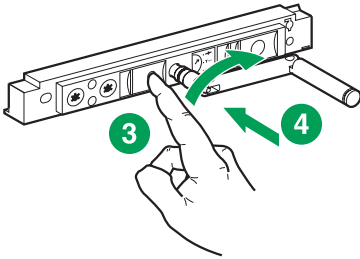

Fig. 38

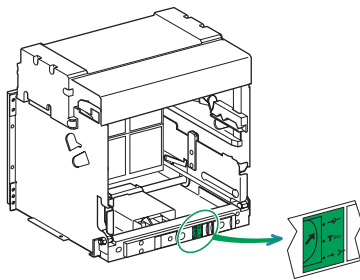

Fig. 39

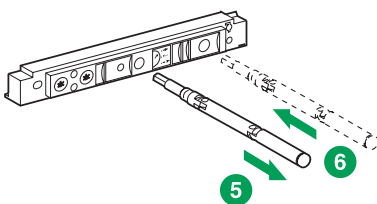

Fig. 40

- Rack in the Masterpact/Easypact devices:
 - Fit the racking crank (see Fig. 37).
 - Turn the crank (see Fig. 38) until "connected" position be indicated (see Fig. 39).

NOTICE

At the end of insertion, considerable effort is required on the crank. This is because the device terminals must be pushed into the fixed contacts. The required torque may be as high as 25 Nm.

- Put the crank back into its lodging (see Fig. 40).
- Insert any disconnectable circuit breakers.
- Check that all protective circuit breakers are in the open (OFF) position.
- Set the control units of the Masterpact/Easypact devices (see the Masterpact/Easypact manual) to protect the network and, if applicable, the low-voltage distribution outgoers.
- Set the trip units on the protective circuit breakers, depending on the rating of each outgoer.
- Set the magnetic release on each of the motor-protection circuit breakers after examining the nameplate of the motor to be protected.
- Check that the phase rotation or index is in conformity with that of the circuits supplying Blokset.
- One after the other, energize the power circuits in the switchboard, checking each time that the loads are supplied and operated correctly.
- Carry out operating tests:
 - Operating sequence
 - Controls, indications, measurements, and protection
 - Remote-control mechanism
 - Electrical interlocks

DANGER

HAZARD OF ELECTRIC SHOCK, BURNS OR EXPLOSION

Energizing the switchboard for the first time is potentially dangerous. Therefore only qualified personnel may carry out the energizing procedure because, faults are caused by shocks or incorrect installation and which are not detected during the preliminary checks, may result in bodily injury and serious damage to the equipment when the power is turned on.

Failure to observe these instructions will result in severe bodily injury or death, and damage to the switchboard.

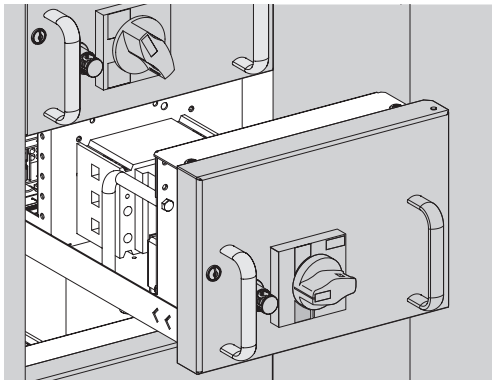

Fig. 1

Mw2

Each functional unit is a real drawer (see Fig. 1), made up of a:

- Withdrawable moving part with power plugs for busbar connection and auxiliary contacts connector.
- Fixed part for interfacing with the busbar and customer connections (power and auxiliaries).

Identification

Each unit is identified by an engraved plate mounted on the door, an identification plate on the drawer, and a mismatch-prevention system (optional).

Description of a motor-feeder unit

Door (see Fig. 2)

- Rotary handle for the circuit breaker "A"
- Optional elements:
 - Green OFF light "B"
 - ON push-button "C"
 - OFF push-button "D"
 - Red ON light "E"
 - Yellow FAULT light "F"

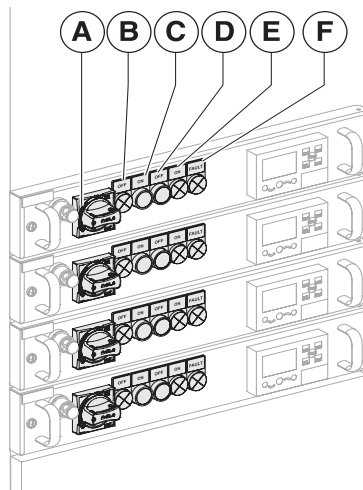

Fig. 2

Drawers parts

Drawer functional units are composed with 3 sets of pieces (see Fig. 4).

- The fixed parts:
 - Main part
 - Customer outgoing (for side or rear connection)
 - Form 4 (for side or rear connection)
- The moving parts:
 - Main part
 - Power plugs
- The front face:
 - Handles
- Auxiliaries parts complete the functional unit:
 - Auxiliary connectors
 - Accessories:
 - Compulsory: index mechanism
 - Optional: mismatching system and microswitches

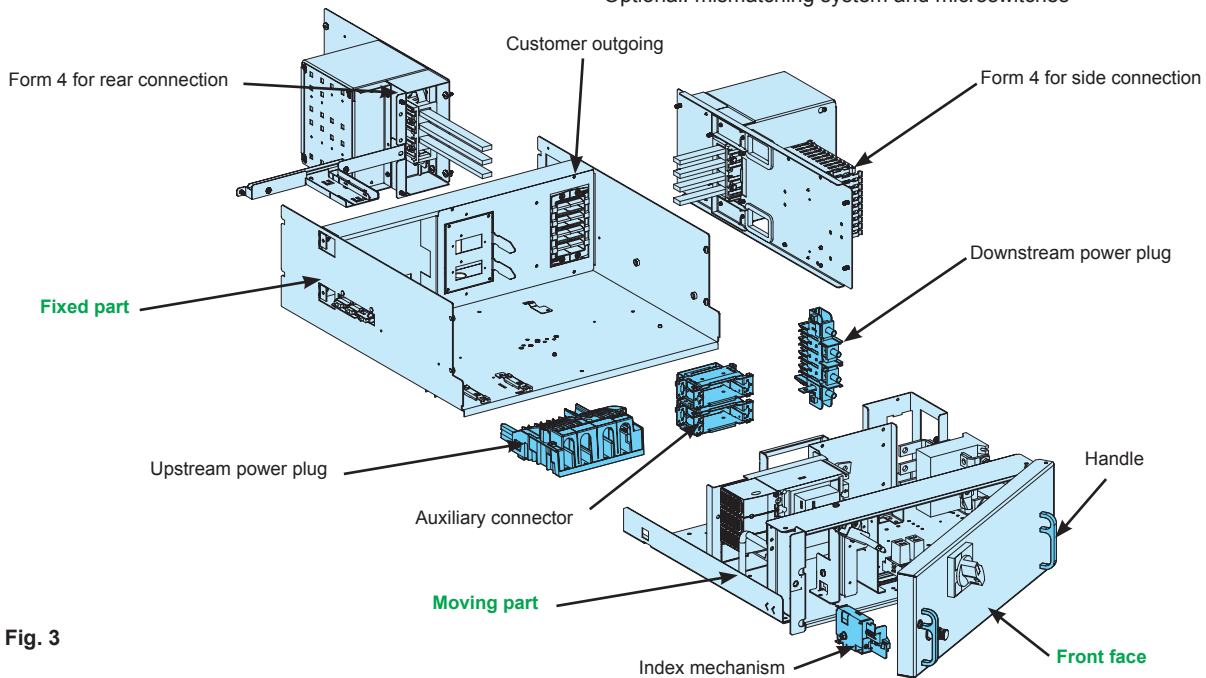

Fig. 3

Positions

The drawer may be set to any of the following positions:

- Connected position (see Fig. 4a)
Power and auxiliary circuits are all connected.
- Test position (see Fig. 4b)
Power circuits are disconnected (upstream and downstream), auxiliary circuits remain connected.
- Disconnected position (see Fig. 4c)
All circuits are disconnected.

Optional front drawer position indicators are also displayed on the front face of the drawer doors. For more details on the mechanical indicator, refer to the Mw2 catalogue.

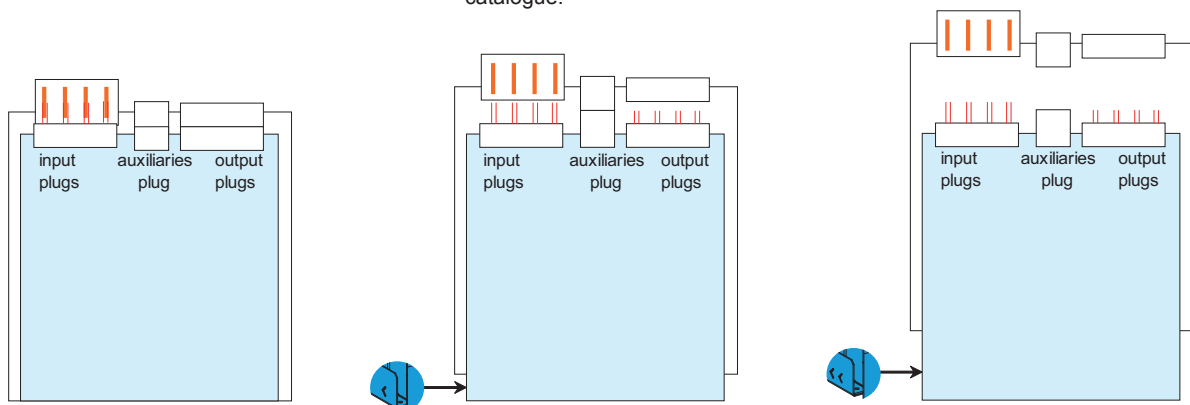

Fig. 4a

Fig. 4b

Fig. 4c

Drawer movement

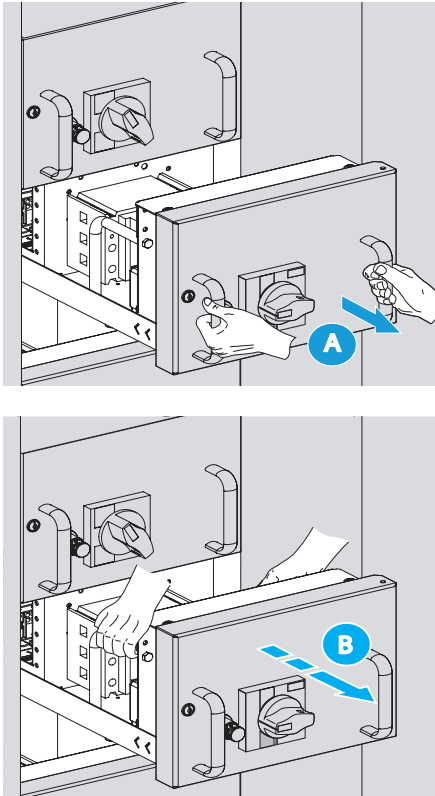

Fig. 5: Drawer movement

Drawer stopper positions

- **General:** Drawer movement from one position to another:
 - Withdrawal of the drawer is not possible when the breaker is in ON/closed condition.
 - To withdraw the drawer:
 - Turn the breaker to OFF/open position.
 - Hold the handle and press the indexing push button simultaneously.
- **Withdrawal:**
 - The drawer is pulled from «connected» to the «test» position, then to the «disconnected» position.
 - Further motion of the drawer is restricted by the drawer stop mechanism.
- **Removal:**
 - Pull the drawer by using the handles to the pre-extraction hard point.
 - To extract the drawer, pull the drawer by pushing the drawer stop lever.
 - Be careful with grease present on the mechanisms.
- **Placing into connected position:**
 - Engage the drawer in its cell by pushing the drawer stopper lever up.
 - Check that the breaker is in OFF/open position.
 - By using the two handles, push the drawer to the «disconnected» position.

NOTICE

If the drawers are equipped with a mismatching device, check the consistence of the drawer and the cell.

Drawer in connected position

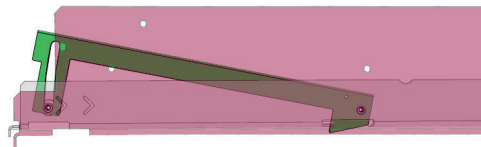

Drawer in pre-extraction hard point position

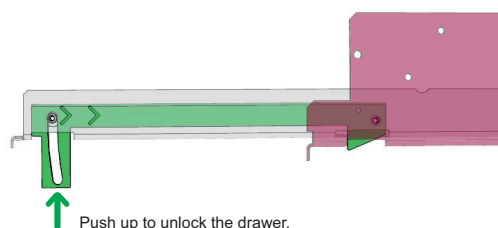

Drawer in extracted position

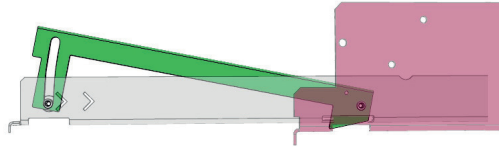

Securing a functional unit

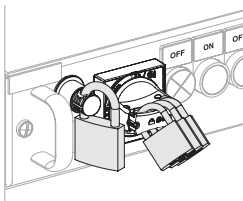

Fig. 6

- Each functional unit can be secured with:
 - 1 to 3 padlocks on the rotary handle.
 - 1 padlock on the push-button.Using the GV2/GV3, the rotary handle can be secured with up to 6 padlocks.

Mw2 Network wiring

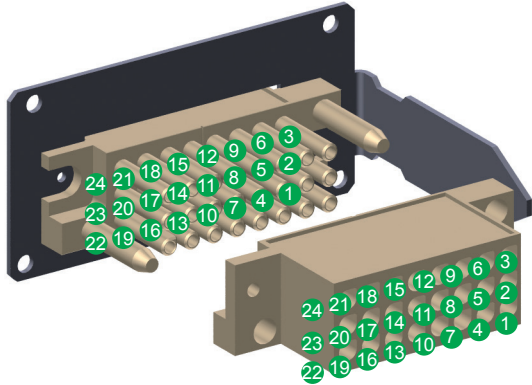

Fig. 7

Contact no.	24	21	18	15	12	9	6	3	
No network	-	-	-	-	-	-	-	-	3
	-	-	-	-	-	-	-	-	2
	-	-	-	-	-	-	-	-	1
Profibus	Bus	Ground	-	-	-	-	-	-	3
	Ground	Ground	-	-	-	-	-	-	2
	Bus	Ground	-	-	-	-	-	-	1
Modbus	Bus	Ground	-	-	-	-	-	-	3
	Ground	Ground	-	-	-	-	-	-	2
	Bus	Ground	-	-	-	-	-	-	1
DeviceNet	Bus	Ground	-	-	-	-	-	-	3
	Ground	Ground	-	-	-	-	-	-	2
	Bus	Ground	-	-	-	-	-	-	1
Modbus TCP-Star	Bus	Bus	Ground	-	-	-	-	-	3
	Ground	Ground	Ground	-	-	-	-	-	2
	Bus	Bus	Ground	-	-	-	-	-	1
Modbus TCP-Daisy chain	Bus	Bus	Ground	Bus	Bus	Ground	-	-	3
	Ground	Ground	Ground	Ground	Ground	Ground	-	-	2
	Bus	Bus	Ground	Bus	Bus	Ground	-	-	1

Consult the Masterpact/Easypact documentation.

To close Masterpact/Easypact (ON position):

Charge the circuit breaker operating mechanism by pulling down the lever seven times until a «Clack» sound is heard. The «charged» indication is displayed (see Fig. 7).

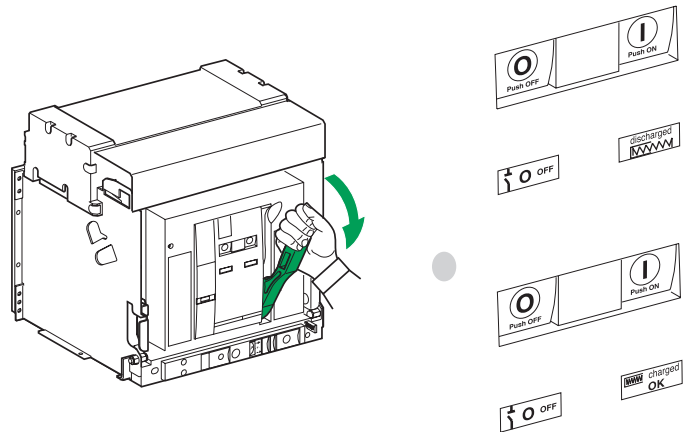

Fig. 7

- If the device trips due to an electrical fault, reset the indicator on the control unit by pushing the **RESET** button (see Fig. 8).

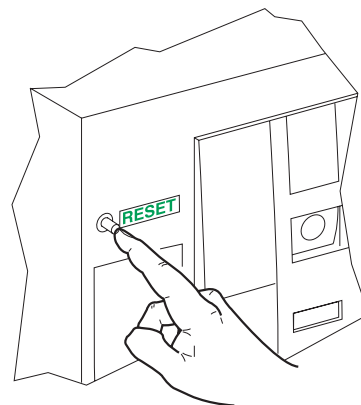

Fig. 8

- Press the **ON** button. The ON indication is displayed (see Fig. 9).

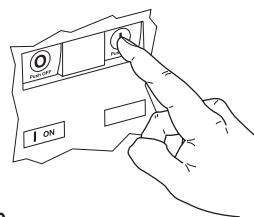

Fig. 9

To open Masterpact/Easypact (OFF position):

Press the OFF button. The OFF indication is displayed (see Fig. 10).

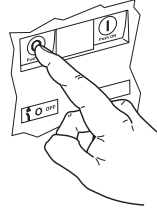



Fig. 10

 DANGER
<p>HAZARD OF ELECTRIC SHOCK, BURNS OR EXPLOSION</p> <p>A hazard of electric shock, burns or explosion exists whenever working in or around the equipment. Blokset must be operated only by a qualified personnel, who is familiar with the installation.</p> <p>Failure to observe these instructions will result in severe bodily injury and damage to the switchboard.</p>

Two types of manual controls are possible:

Direct control on the MCCB:

- Open the door to access the devices (see Fig. 11 and Fig.11a).
- The device is controlled by pushing the toggle up, down, right, or left, depending on how the device is mounted and according to the I and O markings engraved on the case (see Fig. 12).

I = closed (ON)

O = open (OFF)

Extended rotary handle:

The control mechanism is a rotating handle (see Fig. 13 and 14).

To close a Compact circuit breaker or TeSys series:

- Turn the handle towards I (clockwise) to close the circuit breaker.

To open a Compact circuit breaker or TeSys series:

- Turn the handle towards O (counter-clockwise) to open the circuit breaker.

Recharging:

If tripping is automatic or due to a circuit-breaker fault (indicated by the position of the handle), the mechanism must be recharged prior to closing. Turn the handle completely to open position (1). Then, the circuit breaker can now be closed (2) (see Fig. 15).

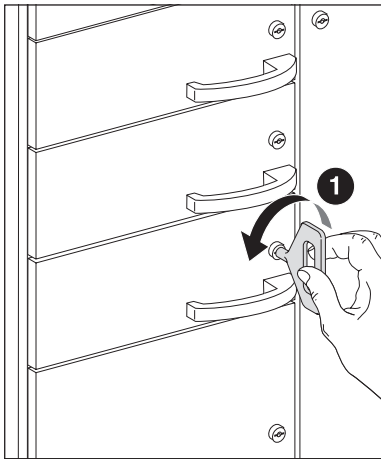

Fig. 11

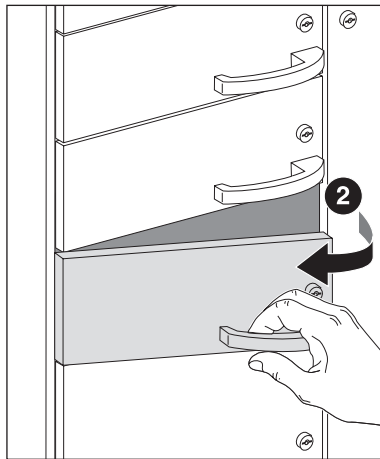

Fig. 11a

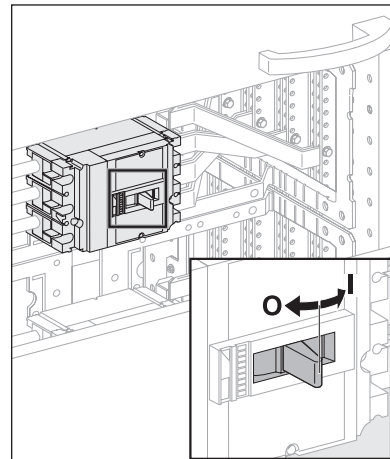

Fig. 12

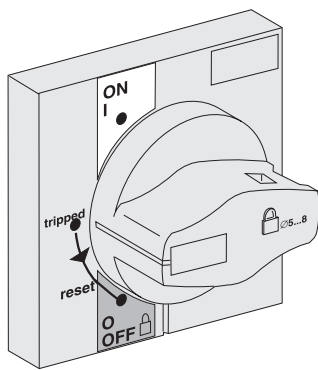

Fig. 13

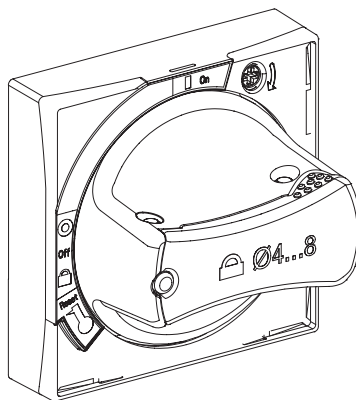

Fig. 14



Fig. 15

In the event of any switchgear device problem, consult the corresponding manuals:

- Blokset switchboard - consult the section on "**Operation**".
- Masterpact/Easypact circuit breakers, consult the corresponding manuals.
- Compact NSX circuit breakers, consult the corresponding manuals.
- TeSys series circuit breakers, consult the corresponding manuals.
- TeSys series contactors and relays, consult the corresponding manuals.

If fault persists, contact your local Schneider Electric office.



HAZARD OF ELECTRIC SHOCK, BURNS OR EXPLOSION

Turn off the power supplying the equipment before working on it. A hazard of electric shock, burns or explosion exists whenever working in or around the equipment.

Failure to observe these instructions will result in severe bodily injury or death.

Periodic checks on Blokset must be carried out in accordance with the applicable regulations.

Periodic maintenance must be carried out once a year or more, depending on the stipulations in the servicing conditions and the maintenance contract.

⚠ DANGER

HAZARD OF ELECTRIC SHOCK, BURNS OR EXPLOSION

Turn off the power supplying the equipment before working on it. A hazard of electric shock, burns or explosion exists whenever working in or around the equipment.

Failure to observe these instructions will result in severe bodily injury or death.

Maintenance on fixed parts of the switchboard (see Fig. 1)

Common maintenance operations for the entire range.

- Check inside and outside the switchboard for moisture or foreign material. Remove any foreign material and clean the switchboard.
 - Use a vacuum cleaner to clean. If necessary, clean the ventilation system and change the filters.
 - Clean old grease off all mechanical parts and regrease lightly (ref. 87635).
 - Examine the outer finish of the switchboard. If necessary, touch up any paint scratches and replace any damaged or rusted parts.
 - Check the insulation monitoring devices.
 - Run tests on the indication systems.
 - Visually check the busbars:
 - Assembly screws for busbars do not require to be tightened as long as the varnish and the guaranteed correct tightening torque, is intact;
 - Visual inspect to detect any hot points (change in colour).
- If a hot point is detected, the assembly must be dismantled. Clean and sand the contact surfaces (sand paper grade 400). When remounting:
- Use identical (class 8.8) new hardware (bolts, nuts and washers).
 - Tighten as indicated in the table below.
 - Apply varnish.
- Visually check the condition and tightness of the busbar supports.
 - Check the tightness of the customer cables.
 - Run a check on the switchgear devices.
 - Consult the corresponding manuals.

This table indicates the correct tightening torque for class 8.8 hardware with nuts and contact washers.

Table indicating tightening torques	
Diameter of bolt	Tightening torque (Nm) nut with contact washer
M3	1.5
M4	3.5
M5	7
M6	13
M8	28
M10	50
M12	75
M14	120
M16	185
M18	260
M20	370

NOTICE

- Do not clean using compressed air to avoid blowing contaminants to other surfaces.
- For cleaning purposes, use dry cloths or cloths dipped in denaturated alcohol. All other products are forbidden.
- Never allow plastic parts (supports for busbars and disconnecting contacts) to come into contact with grease or detergents.



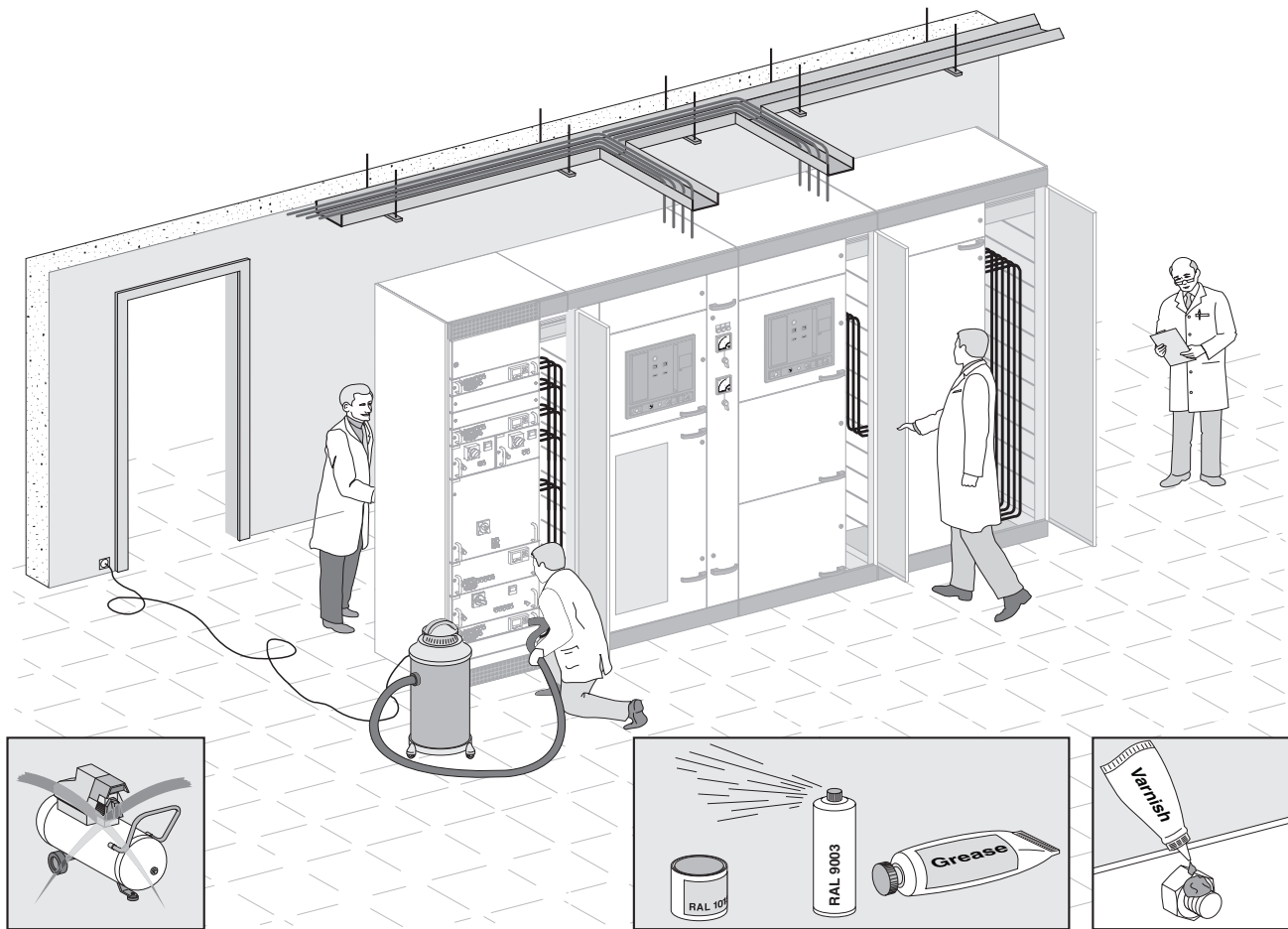



Fig. 1

Checks prior to energizing

- Check the earthing of all exposed conductive parts.
- Check equipotential connections.
- Carry out insulation measurements.

Maintenance after a fault has occurred

The high currents resulting from a fault may cause damage to structures, components, busbars and cables. If fault persists, contact your local Schneider Electric office.

 DANGER
<p>HAZARD OF ELECTRIC SHOCK, BURNS OR EXPLOSION</p> <p>To prevent accidental contact with live parts, all equipments must be de-energized, disconnected and isolated. Before working on the equipment, check that there is no voltage present on any of the incoming and outgoing terminals of the circuit breakers, contactors or starters in the switchboard. Only qualified personnel may carry out inspection and repair procedures and all the safety procedures must be observed.</p> <p>Failure to observe these instructions will result in severe bodily injury or death.</p>

Maintenance on fixed parts of the switchboard (cont.)

- Additional maintenance for withdrawable Blokset switchboards:
- Check the condition of the busbars opposite the disconnection contacts (no corrosion or pitting). Remove any grease from plastic parts.
 - Check the correct position of auxiliary contacts and their condition.
 - Clean the rails and remove any trace of grease. Then lightly regrease (ref. 87635).

Maintenance on drawers



- Perform the following checks during drawer maintenance:
- Check the connection/disconnection mechanism for correct operation. Lightly grease the cam ramp and the connection roller (ref. 87635).
 - Clean the disconnecting contacts. Lightly grease the elements that make electrical contact (ref. 87635).
 - Check that the auxiliary contact blocks on the fixed part move freely.
 - Check the position of the auxiliary contacts on the drawer.
 - Check the condition of the auxiliary contacts.
 - Check all connections.
 - Check the tightness of the connections to the devices (presence of the varnish). If necessary, retighten according to the torque values as mentioned in the tables.
 - Check the switchgear devices (consult the corresponding manuals).

NOTICE
<p>Do not keep adjacent drawers in extracted position (see Fig. 2). Only one drawer should be operated at a time.</p>

Fig. 2

Frequency of preventive maintenance

The frequency of preventive maintenance depends primarily on the operating conditions of the electrical switchboard. For operating conditions found in normal environments, the frequency at which the maintenance should be carried out is indicated in the table below.

The frequency may be lower if the switchboard is used in a particularly clean environment and not in an intensive manner. If the switchboard is used in a particularly aggressive environment (dust, humidity, corrosive vapours, and heat) or is used intensively, the frequency of the maintenance must be higher.

Type	Action	Frequency
General inspection	<ul style="list-style-type: none"> ■ General check ■ General cleaning ■ Greasing of mechanical parts 	Once a year
Maintenance on main busbars	<ul style="list-style-type: none"> ■ Check on contacts 	Every two years (or during a break in production)
Maintenance on switchgear devices	<ul style="list-style-type: none"> ■ According to operating manuals of manufacturers 	
Maintenance on drawers	<ul style="list-style-type: none"> ■ Remove all the drawers. This operation will eliminate any fretting corrosion on the electrical contacts. ■ Visually check the contacts and disconnecting contacts. Apply grease (ref. 87635). ■ Lubricate all moving parts. ■ Retighten all connection points. ■ Check visual appearance and securing of the output connection block on the fixed part. ■ Check the tightness of all the power and control connections. 	<p>Once a year</p> <p>Once a year</p> <p>Once a year</p> <p>Once a year</p> <p>Once a year</p> <p>Once a year</p>

NOTICE

By cleaning, we mean elimination of dust and excess grease using a brush or a dry cloth.
By lubricating, we mean applying grease with a brush to the mating parts of the drawer.

■ **Thermal monitoring for Mw2:**

- Unscrew the 1/4 turn screw.
- Unlock the protection device rotary handle.
- Open the door.
- Execute thermal monitoring.
- Close the door again.

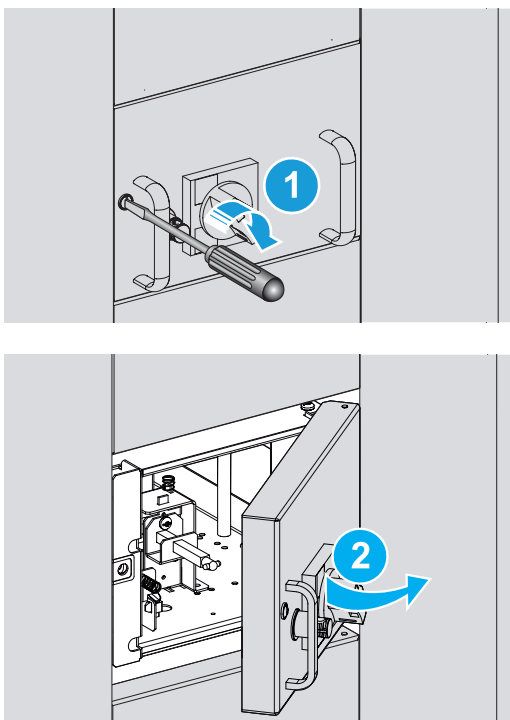

Fig. 3: Mw2

Fixed starter

- Open the door of the mounting space chosen for the extension.
- Install the mounting plate with its starter and the control and indication devices in the frame.
- **Make connections between the:**
 - Starter input and the vertical busbars
 - Starter output and the load
- If applicable, wire the auxiliaries to the customer terminal block (position indication contacts, fault-indication contact, shunt trip).
- Set the protective devices.
- **Prior to energizing, make a preliminary check:**
 - Order of phases
 - Elimination of foreign material (cable scraps, nuts and bolts, and tools)
 - Carry out insulation measurements
- Energize the system.

 **DANGER**
HAZARD OF ELECTRIC SHOCK, BURNS OR EXPLOSION

Turn off the power supplying the equipment before working on it. A hazard of electric shock, burns or explosion exists whenever working in or around the equipment.

Failure to observe these instructions will result in severe bodily injury or death.

Adding a section

NOTICE

The procedure presented below is for the addition of a section on the right-hand side of the Blokset switchboard. For additions on the left-hand side, the procedure is the same, interchange the words left and right.

see Fig. 2

Remove the right side panel of the Blokset switchboard.

- Remove the hooks holding the panel.
- Position the new section next to the switchboard.
- Secure the new section to the floor using M10 anchor bolts.
- Make connections between the two sections using M6x16 bolts.
- Splice the earthing bars.
- Splice the horizontal busbars.
- Connect the outgoers.
- Connect the auxiliaries.
- Refit the panels.
- Prior to energizing, make a preliminary check.
 - Remove all foreign objects that may interfere with the switchboard operation (cable scraps, wires, nuts and bolts, tools and so on).
 - Vacuum the entire switchboard to remove dust.
 - Carry out overall insulation measurements.

If a TNC earthing arrangement is used, disconnect the earth electrodes before carrying out the insulation measurements.

Measurements should be carried out using an insulation tester and with the system supplied by a voltage of at least 500 Vdc.

The insulation-resistance value must be equal to at least 1000 Ω/V.

- Check the electrical continuity of the various exposed conductive parts (presence of contact washers, presence of equipotential connectors for doors, etc.).
- Check the tightness of all the electrical connections, mechanical connections, and the anchor bolts.
 - Miscellaneous checks: mechanical locking of switchgear devices; markings on the switchboard, on power and control conductors.
 - Visual inspection of outside surfaces and paintwork. Touch up any scratches or other defects.
- Then, proceed with energizing.

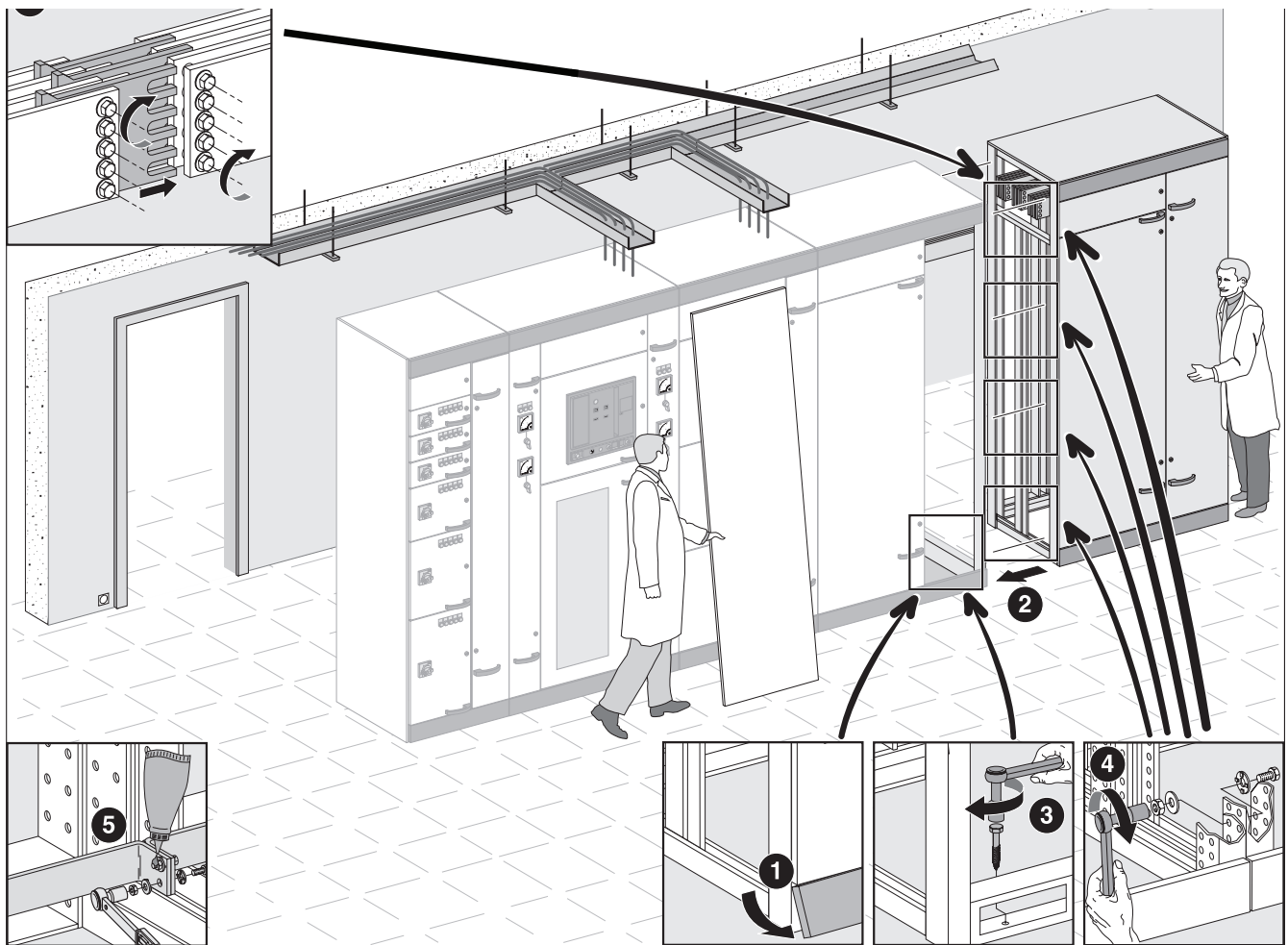
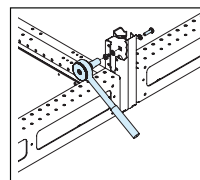

Fig. 2

Adding a section

Assembling



Mw2 / Mw2

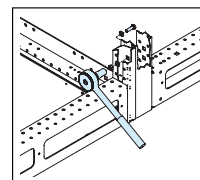

Mw2 / D

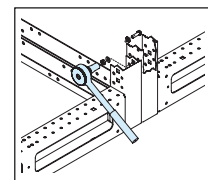

D / D

Fig. 3 : Cubicles are assembled with M6 x 16 screws.

Cubicle evolution

The modular design of Blokset switchboard provides the facility to add extensions or modify functional units.

Installing a new drawer in Mw2:

- Remove front plates to free the space for the new drawer.
- Install the parts to make the fixed part functional (metal parts, proof falling, position guide, index mechanism stop and customer outgoing parts).
- Insert the new drawer.

NOTICE

In any case, it is recommended to wire auxiliary contacts as soon as possible.
In case of half drawer, it is recommended to equip the left one first.

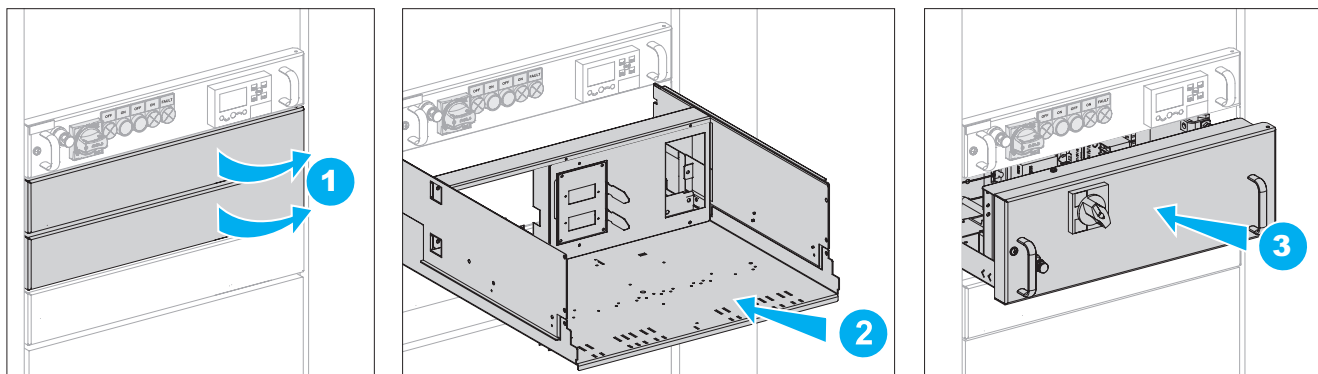

Fig. 4

Schneider Electric Industries SAS

35, rue Joseph Monier
CS 30323
92506 Rueil Malmaison Cedex
France

RCS Nanterre B 954 503 439
Shared capital 896 313 776 €
<http://www.schneider-electric.com>

BLK-024EN_MM_r3

As standards, specification and designs change from time to time. Please, ask for confirmation of the information given in this document.

Design: Schneider Electric
Illustrations: Schneider Electric
Printing: